



MODEL:
AFL3-W07A-AL2

**7" Flat Bezel Panel PC with Intel® Celeron® N3350 CPU,
Touchscreen, Dual USB 3.2 Gen 1, M.2 B-Key Slot,
HDMI, GbE LAN, PoE PD, Wi-Fi 802.11a/b/g/n/ac and RoHS**

User Manual

Revision

Date	Version	Changes
November 29, 2021	1.01	Added Windows 11 support in Table 1-1
January 20, 2021	1.00	Initial release

Copyright

COPYRIGHT NOTICE

The information in this document is subject to change without prior notice in order to improve reliability, design and function and does not represent a commitment on the part of the manufacturer.

In no event will the manufacturer be liable for direct, indirect, special, incidental, or consequential damages arising out of the use or inability to use the product or documentation, even if advised of the possibility of such damages.

This document contains proprietary information protected by copyright. All rights are reserved. No part of this manual may be reproduced by any mechanical, electronic, or other means in any form without prior written permission of the manufacturer.

TRADEMARKS

All registered trademarks and product names mentioned herein are used for identification purposes only and may be trademarks and/or registered trademarks of their respective owners.

Manual Conventions



WARNING

Warnings appear where overlooked details may cause damage to the equipment or result in personal injury. Warnings should be taken seriously.



CAUTION

Cautionary messages should be heeded to help reduce the chance of losing data or damaging the product.



NOTE

These messages inform the reader of essential but non-critical information. These messages should be read carefully as any directions or instructions contained therein can help avoid making mistakes.



HOT SURFACE

This symbol indicates a hot surface that should not be touched without taking care.

Table of Contents

1 INTRODUCTION.....	1
1.1 OVERVIEW.....	2
1.2 FEATURES.....	2
1.3 FRONT PANEL.....	3
1.4 BOTTOM PANEL	4
1.5 REAR PANEL	5
1.6 SYSTEM SPECIFICATIONS.....	5
1.7 DIMENSIONS.....	8
2 UNPACKING	9
2.1 UNPACKING.....	10
2.2 PACKING LIST	11
2.3 OPTIONAL ITEMS.....	11
3 INSTALLATION	13
3.1 ANTI-STATIC PRECAUTIONS.....	14
3.2 INSTALLATION PRECAUTIONS.....	14
3.3 INSTALLATION AND CONFIGURATION STEPS	15
3.4 M.2 SSD INSTALLATION.....	15
3.5 COM1 RS-232/422/485 SELECTION	18
3.5.1 COM1 Pinouts	18
3.5.1 COM1 Pin 9 Selection	18
3.6 FLASH DESCRIPTOR SECURITY OVERRIDE.....	19
3.7 AT/ATX MODE SELECTION.....	20
3.8 MOUNTING THE SYSTEM	20
3.8.1 Wall Mounting.....	21
3.8.2 Panel Mounting.....	24
3.8.3 Cabinet and Rack Installation	26
3.8.4 Arm Mounting	30
3.8.5 Stand Mounting.....	32
3.8.6 V-Stand Mounting.....	33

3.9 POWERING ON THE SYSTEM.....	35
3.10 RESET THE SYSTEM.....	36
3.11 CLEAR CMOS.....	37
3.12 SOFTWARE INSTALLATION.....	37
3.12.1 Driver Download.....	38
4 BIOS SETUP	40
4.1 INTRODUCTION.....	41
4.1.1 Starting Setup.....	41
4.1.2 Using Setup.....	41
4.1.3 Getting Help.....	42
4.1.4 Unable to Reboot after Configuration Changes.....	42
4.1.5 BIOS Menu Bar.....	42
4.2 MAIN.....	43
4.3 ADVANCED.....	44
4.3.1 ACPI Settings.....	45
4.3.2 F81216 Super IO Configuration.....	46
4.3.2.1 Serial Port 1 Configuration.....	46
4.3.3 iWDD H/W Monitor.....	47
4.3.4 USB Configuration.....	48
4.3.5 CPU Configuration.....	50
4.3.6 RTC Wake Settings.....	51
4.3.7 Power Saving Configuration.....	52
4.3.8 Serial Port Console Redirection.....	53
4.3.8.1 Legacy Console Redirection Settings.....	54
4.3.9 IEI Feature.....	55
4.4 CHIPSET.....	56
4.4.1 North Bridge Configuration.....	57
4.4.1.1 Internal IGD Configuration.....	57
4.4.1.2 LCD Control.....	59
4.4.2 South Bridge Configuration.....	60
4.4.2.1 HD-Audio Configuration.....	62
4.4.2.2 PCI Express Configuration.....	63
4.4.2.2.1 M2_AKEY1.....	64
4.4.2.3 SATA Configuration.....	65

AFL3-W07A-AL2 Panel PC

4.5 SECURITY.....	66
4.6 BOOT.....	67
4.7 SAVE & EXIT	69
5 SYSTEM MAINTENANCE	71
5.1 SYSTEM MAINTENANCE INTRODUCTION	72
5.2 ANTI-STATIC PRECAUTIONS.....	72
5.3 TURN OFF THE POWER.....	73
5.4 REMOVING THE BACK COVER	73
5.5 WLAN CARD REPLACEMENT	74
5.6 REINSTALLING THE COVER.....	75
6 INTERFACE CONNECTORS	76
6.1 PERIPHERAL INTERFACE CONNECTORS.....	77
6.2 INTERNAL PERIPHERAL CONNECTORS	78
6.2.1 Battery Connector (BT1).....	78
6.2.2 Debug Port Connector (80PORT1)	79
6.2.3 LVDS Connector (LVDS2)	79
6.2.4 M.2 A-Key Slot (M2_AKEY1)	80
6.2.5 M.2 B-Key Slot (M2_1)	81
6.2.6 Power LED Connector (PW_LED1).....	82
6.2.7 SMBus Connector (EC_CN1)	83
6.2.8 Speaker Connector, Left (SPK_L1)	83
6.2.9 SPI Flash Connector (J_SPI1).....	83
6.2.10 SPI Flash Connector, EC (J_SPI2).....	84
6.2.11 USB 2.0 Connector (TOUCH_USB1)	84
6.2.12 USB 2.0 Connectors (USB2_1, USB2_2)	84
6.3 EXTERNAL INTERFACE PANEL CONNECTORS.....	85
6.3.1 Ethernet Connectors (LAN1)	85
6.3.2 HDMI Connector (HDMI1)	86
6.3.3 RS-232/422/485 DB-9 Serial Port (COM1).....	86
6.3.4 Power Connector (PWR1).....	87
6.3.5 USB 3.2 Gen 1 Connectors (USB3-1).....	87
A REGULATORY COMPLIANCE	88
B SAFETY PRECAUTIONS	93

B.1 SAFETY PRECAUTIONS	94
<i>B.1.1 General Safety Precautions</i>	94
<i>B.1.2 Anti-static Precautions</i>	95
<i>B.1.3 Product Disposal</i>	96
B.2 MAINTENANCE AND CLEANING PRECAUTIONS	97
<i>B.2.1 Maintenance and Cleaning</i>	97
<i>B.2.2 Cleaning Tools</i>	97
C BIOS MENU OPTIONS	99
D WATCHDOG TIMER	102
E ERROR BEEP CODE	105
E.1 PEI BEEP CODES.....	106
E.2 DXE BEEP CODES	106
F HAZARDOUS MATERIALS DISCLOSURE	107
F.1 RoHS II DIRECTIVE (2015/863/EU)	108
F.2 CHINA RoHS.....	109

List of Figures

Figure 1-1: AFL3-W07A-AL2 Flat Bezel Panel PC	2
Figure 1-2: Front View	3
Figure 1-3: Bottom Panel	4
Figure 1-4: Rear View	5
Figure 1-5: Dimensions (mm)	8
Figure 3-1: Back Cover Retention Screws	16
Figure 3-2: Open the Back Cover	16
Figure 3-3: M.2 Slot Location	17
Figure 3-4: M.2 SSD Installation	17
Figure 3-5: DB-9 Serial Port Pin 9 Setting Jumper Location	19
Figure 3-6: Flash Descriptor Security Override Jumper Location	19
Figure 3-7: AT/ATX Switch Location	20
Figure 3-8: Wall-mounting Bracket	21
Figure 3-9: Chassis Support Screws	23
Figure 3-10: Secure the Panel PC	23
Figure 3-11: Cutout Dimensions	24
Figure 3-12: Panel Mounting Kit Installation	25
Figure 3-13: Securing Panel Mounting Brackets	26
Figure 3-14: Rack/Cabinet Bracket Installation	27
Figure 3-15: Rack Mounting Kit Installation	28
Figure 3-16: Securing Rack Mounting Brackets	29
Figure 3-17: Install into a Rack/Cabinet	29
Figure 3-18: Arm Mounting Retention Screw Holes	31
Figure 3-19: Arm Mounting	31
Figure 3-20: Stand Mounting (Stand-A/Bxx)	32
Figure 3-21: Drill Pilot Holes for V-Stand	33
Figure 3-22: Secure V-Stand to System	34
Figure 3-23: Secure V-Stand to Mounting Area	34
Figure 3-24: Powering On the System	35
Figure 3-25: Reset Button Location	36
Figure 3-26: Clear CMOS Button Location	37

Figure 3-27: IEI Resource Download Center.....37
Figure 5-1: Back Cover Retention Screws74
Figure 5-2: WLAN Card Location75
Figure 6-1: Main Board Layout Diagram (Front Side).....77
Figure 6-2: Main Board Layout Diagram (Solder Side).....77

List of Tables

Table 1-1: System Specifications.....	7
Table 3-1: RS-232/422/485 Serial Port Pinouts	18
Table 3-2: DB-9 Serial Port Pin 9 Setting Jumper Settings	18
Table 3-3: Flash Descriptor Security Override Jumper Settings.....	19
Table 6-1: BIOS Navigation Keys	42
Table 6-1: Peripheral Interface Connectors	78
Table 6-2: Battery Connector (BT1) Pinouts.....	78
Table 6-3: Debug Port Connector (80PORT1) Pinouts.....	79
Table 6-4: LVDS Connector (LVDS2) Pinouts.....	80
Table 6-5: M.2 A-Key Slot (M2_AKEY1) Pinouts.....	81
Table 6-6: M.2 B-Key Slot (M2_1) Pinouts.....	82
Table 6-7: Power LED Connector (PW_LED1) Pinouts.....	82
Table 6-8: SMBus Connector (EC_CN1) Pinouts.....	83
Table 6-9: Left Speaker Connector (SPK_L1) Pinouts.....	83
Table 6-10: SPI Flash Connector (J_SPI1) Pinouts.....	83
Table 6-11: EC SPI Flash Connector (J_SPI2) Pinouts.....	84
Table 6-12: USB 2.0 Connector (TOUCH_USB1) Pinouts.....	84
Table 6-13: USB 2.0 Connectors (USB2_1, USB2_2) Pinouts.....	84
Table 6-14: Rear Panel Connectors	85
Table 6-15: Ethernet Connectors (LAN1) Pinouts	85
Table 6-16: Ethernet Connector LEDs.....	85
Table 6-17: HDMI Connector (HDMI1) Pinouts.....	86
Table 6-18: RS-232/422/485 DB-9 Serial Port (COM1) Pinouts.....	86
Table 6-19: Power Connector (PWR1) Pinouts.....	87
Table 6-20: USB 3.2 Gen 1 Connectors (USB3-1) Pinouts.....	87

List of BIOS Menus

BIOS Menu 1: Main	43
BIOS Menu 2: Advanced	44
BIOS Menu 3: ACPI Settings	45
BIOS Menu 4: F81216 Super IO Configuration	46
BIOS Menu 5: Serial Port n Configuration Menu	46
BIOS Menu 6: iWDD H/W Monitor	47
BIOS Menu 7: USB Configuration	48
BIOS Menu 8: CPU Configuration	50
BIOS Menu 9: RTC Wake Settings	51
BIOS Menu 10: Power Saving Configuration	52
BIOS Menu 11: Serial Port Console Redirection	53
BIOS Menu 12: Legacy Console Redirection Settings	54
BIOS Menu 13: IEI Feature	55
BIOS Menu 14: Chipset	56
BIOS Menu 15: North Bridge Configuration	57
BIOS Menu 16: Internal IGD Configuration	57
BIOS Menu 17: LCD Control	59
BIOS Menu 18: South Bridge Configuration	60
BIOS Menu 19: HD-Audio Configuration	62
BIOS Menu 20: PCI Express Configuration	63
BIOS Menu 21: M2_AKEY1	64
BIOS Menu 22: SATA Configuration	65
BIOS Menu 23: Security	66
BIOS Menu 24: Boot	67
BIOS Menu 25: Save & Exit	69

Chapter

1

Introduction

1.1 Overview



Figure 1-1: AFL3-W07A-AL2 Flat Bezel Panel PC

The AFL3-W07A-AL2 is a dual-core Intel® Celeron® processor N3350 powered flat bezel panel PC with a rich variety of functions and peripherals. The compact design is ideal for easy and simplified integration into kiosk and point-of-sales (POS) applications.

The Intel® Celeron® N3350 is a SoC (System-on-Chip) that ensures optimal memory, graphics, and peripheral I/O support. The system comes with 4.0 GB of DDR3L SO-DIMM ensuring smooth data throughputs with reduced bottlenecks and fast system access.

Two external USB 3.2 Gen 1 ports and one external RS-232/422/485 port ensure simplified connectivity to a variety of external peripheral devices. Wi-Fi capabilities and the RJ-45 Ethernet connector provide the system with smooth connection to an external LAN. Moreover, PoE PD is supported by the Ethernet connector.

1.2 Features

The AFL3-W07A-AL2 features are listed below:

- 7" flat-bezel LCD with LED backlight
- Intel® Celeron® processor N3350 (up to 2.4 GHz, dual-core)
- Pre-installed 4 GB DDR3L SO-DIMM memory
- PoE PD support
- 2-point anti-glare/anti-UV multi-touch projected capacitive type touchscreen
- Wi-Fi 802.11a/b/g/n/ac high speed wireless and Bluetooth v4.1
- One 2 W speaker
- IP 65 compliant front panel

AFL3-W07A-AL2 Panel PC

1.3 Front Panel

The front side of the AFL3-W07A-AL2 is a flat-bezel panel with a 7" TFT LCD screen surrounded by a PC/ABS plastic frame (**Figure 1-2**).

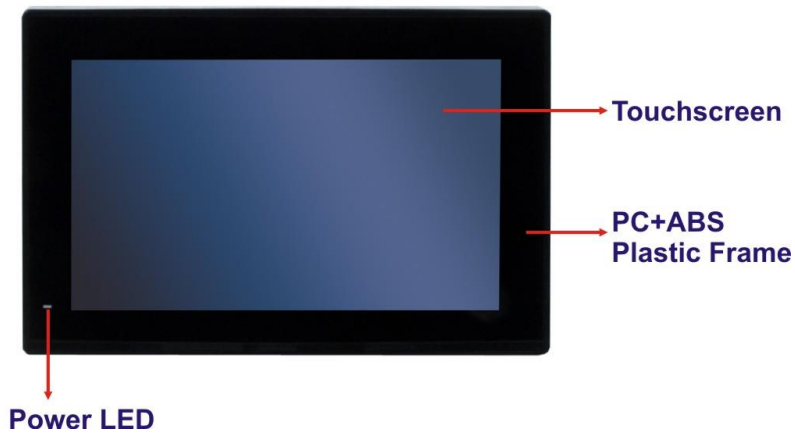

Figure 1-2: Front View

There is a power LED indicator located on the front panel. The status descriptions of the power LED indicator are listed below.

- **Off:** power cord not attached or power supply failure
- **Solid amber:** the system is connected to a power source via **DC** input, and is ready to be turned on.
- **Slow blinking amber:** the system is connected to a power source via **PoE** input, and is ready to be turned on.
- **Solid green:** the system is turned on.

1.4 Bottom Panel

The bottom panel of the AFL3-W07A-AL2 has the following connectors and switches (Figure 1-6):

- 1 x 12 V DC input power jack
- 1 x GbE LAN / PoE RJ-45 connector
- 1 x RS-232/422/485 connector
- 1 x HDMI output connector
- 2 x USB 3.2 Gen 1 connector
- 1 x AT/ATX switch
- 1 x Power button
- 1 x Reset button
- 1 x Clear CMOS button

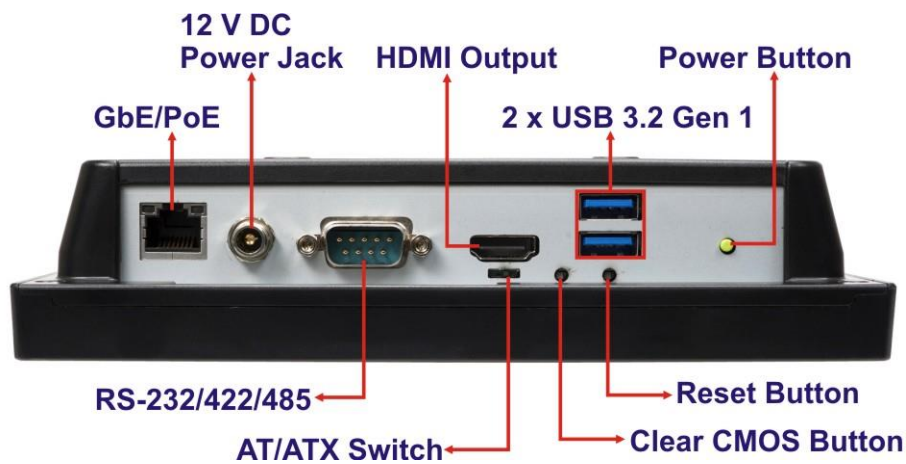

Figure 1-3: Bottom Panel



WARNING:

When using PoE to power the AFL3-W07A-AL2,

1. the total power of the two USB ports must not exceed 5 watts.
2. the suggested operating temperature range is -20°C ~ 35°C.

AFL3-W07A-AL2 Panel PC

1.5 Rear Panel

The rear panel provides access to retention screw holes that support VESA mounting. See **Figure 1-5**.



1

Figure 1-4: Rear View

1.6 System Specifications

The technical specifications for the AFL3-W07A-AL2 systems are listed in **Table 1-4**.

Specification	AFL3-W07A-AL2
LCD Size	7" (16:9)
Max. Resolution	1024 (W) x 600 (H)
Brightness (cd/m2)	500
Contrast Ratio	700:1
LCD Color	16.2M
Viewing Angle (H-V)	150° / 145°
Backlight	LED backlight (MTBF: 20,000 hrs)
Touchscreen	Anti-glare/anti-UV multi-touch projected capacitive type with USB interface (Touch controller: EETI EXC 80H60)
CPU (SoC)	Intel® Celeron® processor N3350

	(up to 2.4 GHz, 2M cache, dual-core, TDP 6 W)
Ethernet	One Intel® I211 PCIe GbE controller
Memory	One 204-pin 1866 MHz DDR3L SO-DIMM slot preinstalled with 4 GB SDRAM (system max. 8 GB)
Storage	One M.2 B+M key 2242 card slot (USB/SATA signal) for SSD installation
Audio	Realtek ALC888S HD Audio codec
Speaker	One 2 W stereo speaker (left channel output only)
Wireless	One 802.11a/b/g/n/ac wireless LAN module (via M.2 A-key 2230 slot with PCIe/USB signal) supports Bluetooth v4.1
Construction Material	PC+ABS plastic front frame
Mounting	VESA 75 mm x 75 mm (panel, wall, rack, stand or arm mounting)
Front Panel Color	Black
Net/Gross Weight	0.73 kg / 1.81 kg
Dimensions (W x H x D)	191 mm x 127 mm x 43 mm
Operating Temperature	DC-in: -20°C ~ 40°C PoE: -20°C ~ 35°C
Storage Temperature	-20°C ~ 60°C
Humidity	10% ~ 95% (non-condensing)
IP Level	IP 65 compliant front panel
Power Supply	36 W power adapter Input: 100 V ~ 240 V AC, 50 Hz ~ 60 Hz Output: 12 V DC, 3A
Power Requirement	12 V DC
Power Consumption	12 V @ 3 A
PoE (PD)	Supported by on-board PoE chip

AFL3-W07A-AL2 Panel PC

	51-57V DC, 0.5A max. (for IEEE802.3at)
Safety/EMC	CE, FCC class A
Erp	ErP 2009/125/EC
Supported OS	Microsoft Window 10 / Windows 11, Linux
I/O Ports and Switches	1 x GbE LAN (RJ-45, supports PoE)
	1 x HDMI output connector
	1 x RS-232/422/485 DB-9 connector
	2 x USB 3.2 Gen 1 (5Gb/s) connectors
	1 x 12 V DC input jack
	1 x Power button
	1 x Reset button
	1 x Clear CMOS button
	1 x AT/ATX switch

Table 1-1: System Specifications



NOTE:

When both DC-in and PoE are connected to the device, the DC-in will be used as the main power source. Disconnecting DC-in while the system is running may lead to system shutdown or reboot.

To switch to the PoE mode, shut down the system, disconnect DC-in, and provide power through the PoE port.

1.7 Dimensions

The AFL3-W07A-AL2 dimensions are shown below.

- **Width:** 190.9 mm
- **Height:** 127.3 mm
- **Depth:** 43.4 mm

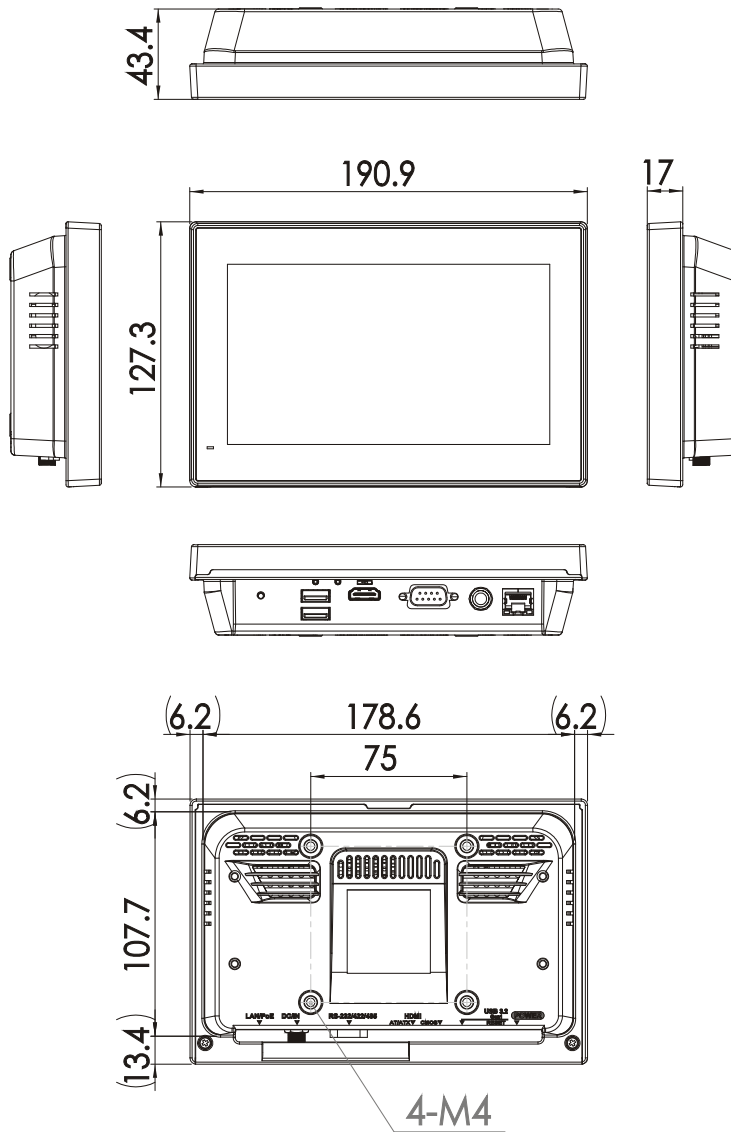

Figure 1-5: Dimensions (mm)

Chapter

2

Unpacking

2.1 Unpacking

To unpack the flat bezel panel PC, follow the steps below:



WARNING!





The front side LCD screen has a protective plastic cover stuck to the screen. Only remove the plastic cover after the flat bezel panel PC has been properly installed. This ensures the screen is protected during the installation process.

- Step 1:** Use box cutters, a knife or a sharp pair of scissors that seals the top side of the external (second) box.
- Step 2:** Open the external (second) box.
- Step 3:** Use box cutters, a knife or a sharp pair of scissors that seals the top side of the internal (first) box.
- Step 4:** Lift the monitor out of the boxes.
- Step 5:** Remove both polystyrene ends, one from each side.
- Step 6:** Pull the plastic cover off the flat bezel panel PC.
- Step 7:** Make sure all the components listed in the packing list are present.

AFL3-W07A-AL2 Panel PC

2.2 Packing List

The AFL3-W07A-AL2 flat bezel panel PC is shipped with the following components:

Quantity	Item	Image
1	AFL3-W07A-AL2 panel PC	
1	Power adapter (36 W)	
1	Power cord	
4	Screws for VESA mounting	
1	Thermal pad for M.2 SSD module	

2.3 Optional Items

The following are optional components which may be separately purchased:

Item and Part Number	Image
VESA 75 wall mount kit (P/N: AFLWK-12)	

Item and Part Number	Image
Panel mounting kit (P/N: AFL3PK-W07A-R11)	
Rack mount kit (P/N: AFL3RK-W07A-R11)	
Arm (P/N: ARM-11-RS)	
Arm (P/N: ARM-31-RS)	
Stand (P/N: STAND-100-RS)	
LCD monitor stand with adjustable hinge (P/N: VSTAND-A07-R11)	

If any of these items are missing or damaged, contact the distributor or sales representative immediately.

Chapter

3

Installation

3.1 Anti-static Precautions

**WARNING:**

Failure to take ESD precautions during the maintenance of the AFL3-W07A-AL2 may result in permanent damage to the AFL3-W07A-AL2 and severe injury to the user.

Electrostatic discharge (ESD) can cause serious damage to electronic components, including the AFL3-W07A-AL2. Dry climates are especially susceptible to ESD. It is therefore critical that whenever the AFL3-W07A-AL2 is accessed internally, or any other electrical component is handled, the following anti-static precautions are strictly adhered to.

- ***Wear an anti-static wristband:*** Wearing a simple anti-static wristband can help to prevent ESD from damaging the board.
- ***Self-grounding:*** Before handling the board, touch any grounded conducting material. During the time the board is handled, frequently touch any conducting materials that are connected to the ground.
- ***Use an anti-static pad:*** When configuring the AFL3-W07A-AL2, place it on an anti-static pad. This reduces the possibility of ESD damaging the AFL3-W07A-AL2.
- ***Only handle the edges of the PCB:*** When handling the PCB, hold the PCB by the edges.

3.2 Installation Precautions

When installing the flat bezel panel PC, please follow the precautions listed below:

- **Power turned off:** When installing the flat bezel panel PC, make sure the power is off. Failing to turn off the power may cause severe injury to the body and/or damage to the system.
- **Certified Engineers:** Never open the equipment. For safety reasons, the equipment should be opened only by qualified skilled person. Only certified engineers should install and modify onboard functionalities.

AFL3-W07A-AL2 Panel PC

- **Anti-static Discharge:** If a user open the rear panel of the flat bezel panel PC, to configure the jumpers or plug in added peripheral devices, ground themselves first and wear an anti-static wristband.

3.3 Installation and Configuration Steps

The following installation steps must be followed.

Step 1: Unpack the flat bezel panel PC.

Step 2: Install an M.2 SSD.

Step 3: Configure the system.

Step 4: Connect peripheral devices to the flat bezel panel PC.

Step 5: Mount the flat bezel panel PC.

3.4 M.2 SSD Installation



WARNING:

Over-tightening back cover screws will crack the plastic frame.
Maximum torque for cover screws is 5 kg-cm (0.36 lb-ft/0.49 Nm).

To install an M.2 SSD into the AFL3-W07A-AL2, please follow the steps below:

Step 1: Remove two (2) retention screws from the back cover (**Figure 3-1**).



Figure 3-1: Back Cover Retention Screws

Step 2: Remove the back cover from the device. See **Figure 3-2**.



Figure 3-2: Open the Back Cover

Step 3: Locate the M.2 B-key 2242 slot. Remove the preinstalled retention screw on the screw pillar of the M.2 slot as shown in **Figure 3-3**.

AFL3-W07A-AL2 Panel PC

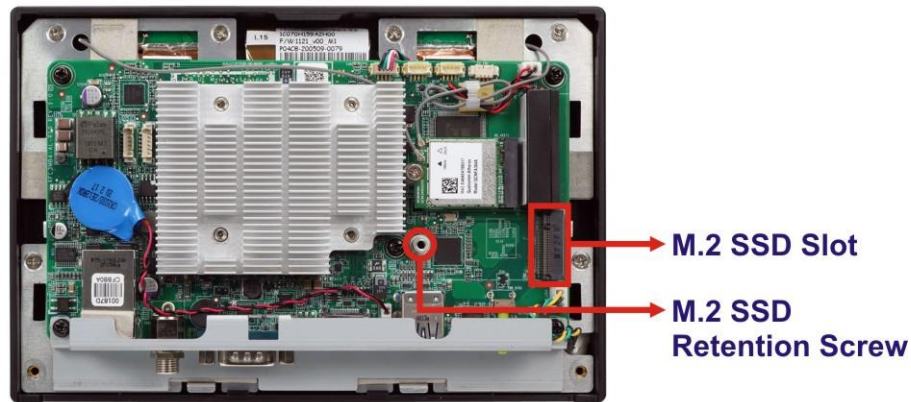

Figure 3-3: M.2 Slot Location

Step 4: Line up the notch on the M.2 SSD with the notch on the connector. Slide the M.2 SSD into the socket at an angle of about 20° (Figure 3-4).

Step 5: Secure the M.2 SSD with the retention screw. Push the other end of the M.2 SSD down and secure the card with the previously removed retention screw (Figure 3-4).

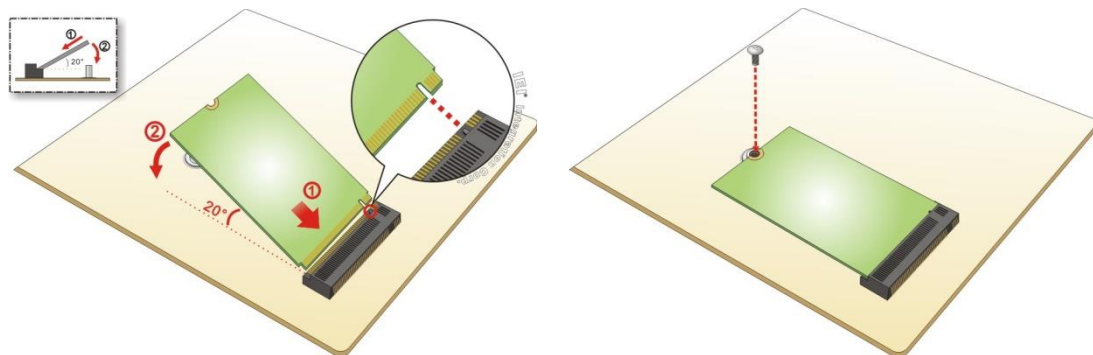

Figure 3-4: M.2 SSD Installation

Step 6: IMPORTANT! Attach the thermal pad come with the system onto the SSD module. The sticky side must face down.

Step 7: Reinstall the back cover and secure it using the retention screws.

3.5 COM1 RS-232/422/485 Selection

The bottom panel of the AFL3-W07A-AL2 has one D-sub 9 male connector for RS-232/422/485 connection. The serial communication mode selection can be made through the BIOS options. Please refer to **Section 4.3.2.1** for detail information.

3.5.1 COM1 Pinouts

The pinouts of COM1 are detailed below.

Pin	RS-232	RS-422	RS-485
1	DCD	TXD422-	TXD485-
2	RX	TXD422+	TXD485+
3	TX	RXD422+	
4	DTR	RXD422-	
5	GND		
6	DSR		
7	RTS		
8	CTS		
9	RI		

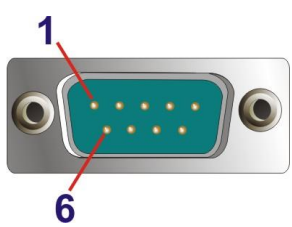

Table 3-1: RS-232/422/485 Serial Port Pinouts

3.5.1 COM1 Pin 9 Selection

The JP1 jumper configures pin 9 on the DB-9 serial port. Pin 9 on the COM1 DB-9 connector can be set as the ring (RI) signal, +5 V or +12 V. The jumper selection options are shown in **Table 3-2**.

JP1	Description
Short 1-2	COM1 RI Pin use +5 V
Short 3-4	COM1 RI Pin use RI (Default)
Short 5-6	COM1 RI Pin use +12 V

Table 3-2: DB-9 Serial Port Pin 9 Setting Jumper Settings

The DB-9 Serial Port Pin 9 Setting jumper location is shown in **Figure 3-5** below.

AFL3-W07A-AL2 Panel PC

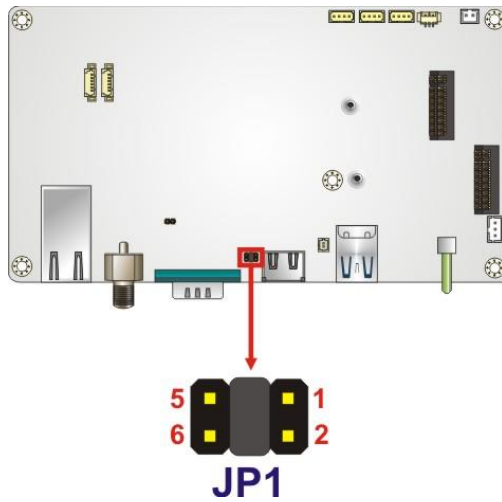

Figure 3-5: DB-9 Serial Port Pin 9 Setting Jumper Location

3.6 Flash Descriptor Security Override

The Flash Descriptor Security Override jumper (J_TXE1) allows to enable or disable the ME firmware update. Refer to **Figure 3-6** and **Table 3-3** for the jumper location and settings.

Setting	Description
Open	Disabled (default)
Short	Enabled

Table 3-3: Flash Descriptor Security Override Jumper Settings

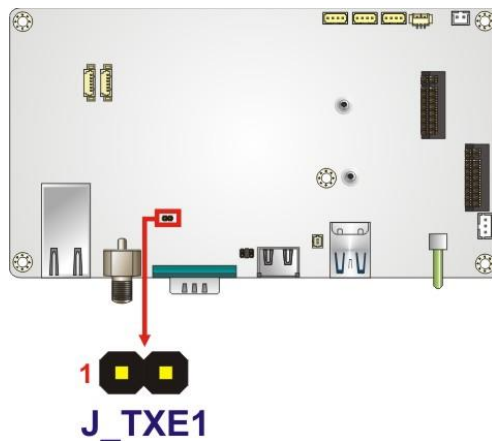

Figure 3-6: Flash Descriptor Security Override Jumper Location

To update the ME firmware, please follow the steps below.

- Step 1:** Before turning on the system power, short the Flash Descriptor Security Override jumper.
- Step 2:** Update the BIOS and ME firmware, and then turn off the system power.
- Step 3:** Remove the metal clip on the Flash Descriptor Security Override jumper.
- Step 4:** Restart the system. The system will reboot 2 ~ 3 times to complete the ME firmware update.

3.7 AT/ATX Mode Selection

AT or ATX power mode can be used on the AFL3-W07A-AL2. The selection is made through an AT/ATX switch located on the bottom panel (**Figure 3-7**).

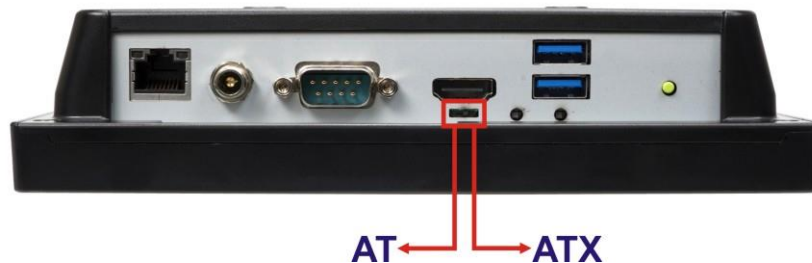

Figure 3-7: AT/ATX Switch Location

3.8 Mounting the System

The methods of mounting the AFL3-W07A-AL2 are listed below.

- Wall mounting
- Panel mounting
- Rack mounting
- Arm mounting
- Stand mounting
- V-Stand mounting

AFL3-W07A-AL2 Panel PC

The mounting methods are described below.

3.8.1 Wall Mounting

To mount the flat bezel panel PC onto the wall, please follow the steps below.

- Step 1:** Select the location on the wall for the wall-mounting bracket.
- Step 2:** Carefully mark the locations of the four screw holes in the bracket on the wall.
- Step 3:** Drill four pilot holes at the marked locations on the wall for the bracket retention screws.
- Step 4:** Align the wall-mounting bracket screw holes with the pilot holes.
- Step 5:** Secure the mounting-bracket to the wall by inserting the retention screws into the four pilot holes and tightening them (**Figure 3-8**).

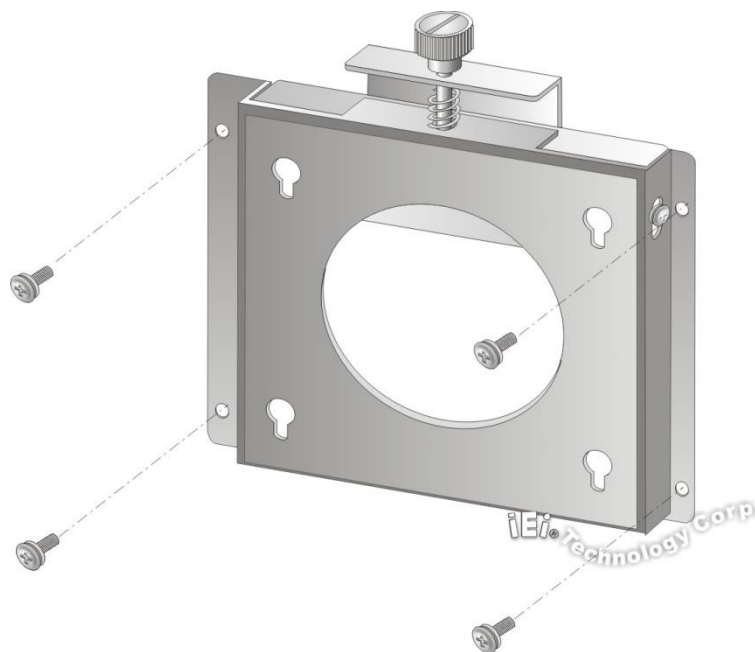
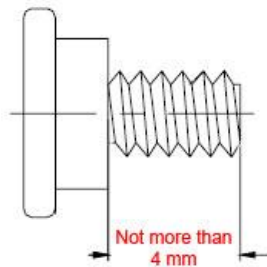

Figure 3-8: Wall-mounting Bracket

Step 6: Insert the four monitor mounting screws provided in the wall mount kit into the four screw holes on the rear panel of the flat bezel panel PC and tighten until the screw shank is secured against the rear panel (**Figure 3-9**).

**WARNING:**

Please use the M4 screws provided in the wall mount kit for the rear panel. If the screw is missing, the thread depth of the replacement screw should be not more than 4 mm.



Step 7: Align the mounting screws on the monitor rear panel with the mounting holes on the bracket.

Step 8: Carefully insert the screws through the holes and gently pull the monitor downwards until the monitor rests securely in the slotted holes (**Figure 3-9**). Ensure that all four of the mounting screws fit snugly into their respective slotted holes.

**NOTE:**

In the diagram below the bracket is already installed on the wall.

AFL3-W07A-AL2 Panel PC

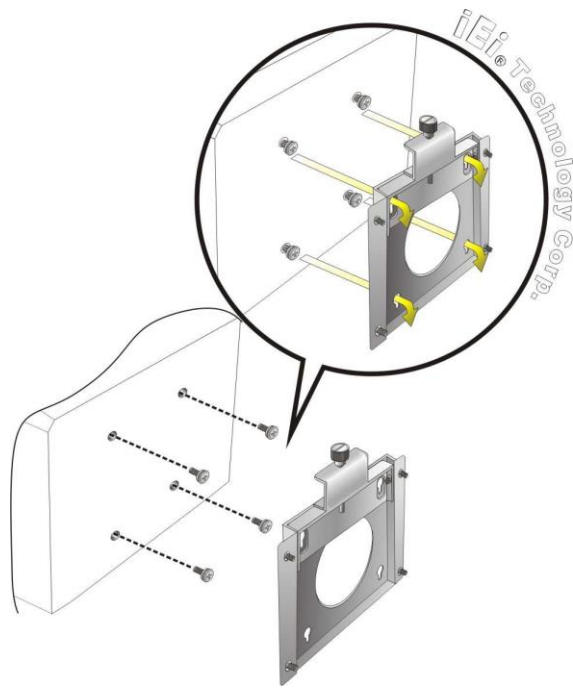

Figure 3-9: Chassis Support Screws

Step 9: Secure the panel PC by fastening the retention screw of the wall-mounting bracket. (Figure 3-10).

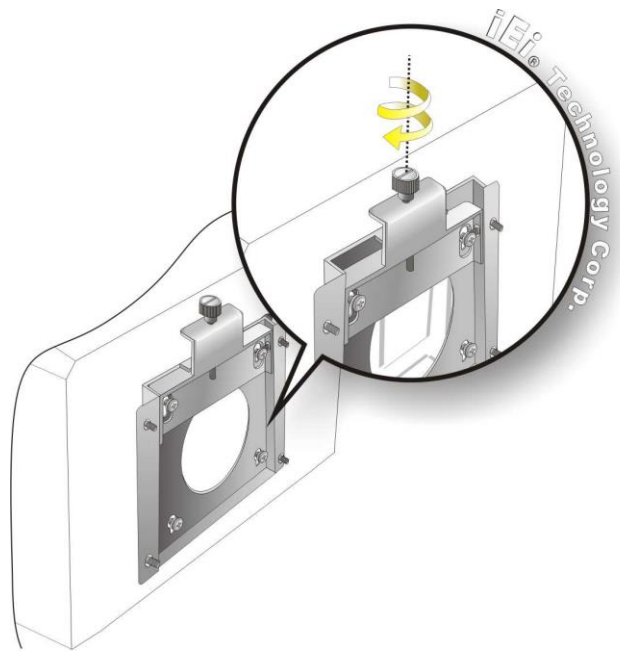

Figure 3-10: Secure the Panel PC

3.8.2 Panel Mounting

To mount the AFL3-W07A-AL2 flat bezel panel PC into a panel, please follow the steps below.

- Step 1:** Select the position on the panel to mount the flat bezel panel PC.
- Step 2:** Cut out a section corresponding to the size shown below. The size must be smaller than the outer edge.

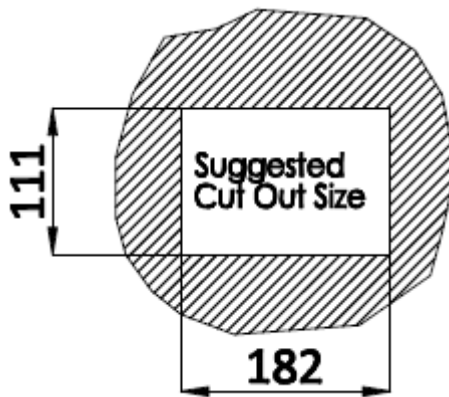

Figure 3-11: Cutout Dimensions

- Step 3:** Slide the flat bezel panel PC through the hole until the frame is flush against the panel.
- Step 4:** Insert a M5*50 screw into the screw hole on the side of the panel mounting bracket. Then, install the following components onto the screw in sequence.

See **Figure 3-12**.

Sequence	Item	Photo	Instruction
1	Spring		Install a spring onto the screw.
2	Nut		Tighten a nut until the spring is compressed enough for plastic cap.
3	Plastic cap		Tighten a plastic cap onto the end of screw thread.

AFL3-W07A-AL2 Panel PC

Step 5: Repeat **Step 4** to install the other three screws into the sides of the two panel mounting brackets.

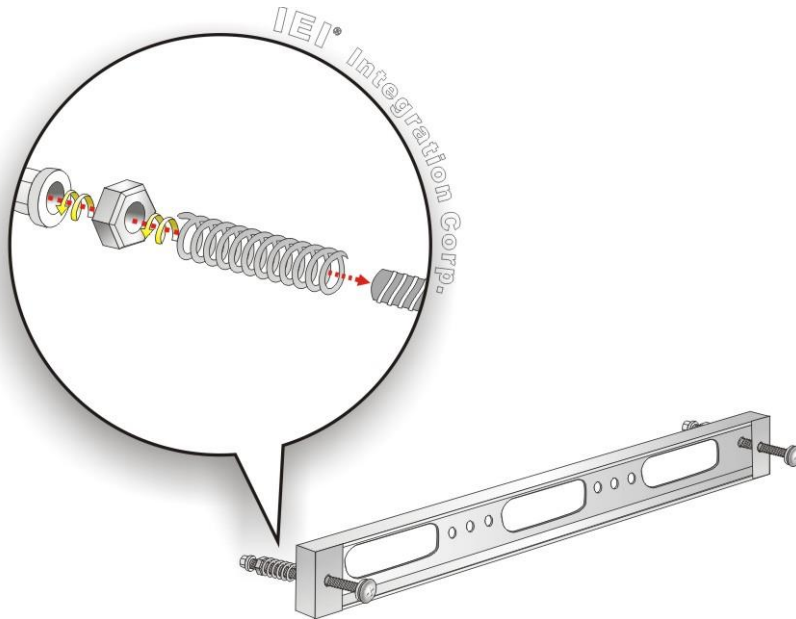

Figure 3-12: Panel Mounting Kit Installation

Step 6: Align the panel mounting bracket screw holes with the VESA mounting holes on the rear of the panel PC.

Step 7: Secure the two panel mounting brackets to the rear of the panel PC by inserting the four retention screws into the VESA mounting holes and tightening them (**Figure 3-13**).



NOTE:

The panel mounting kit described in this section is an optional item. To purchase it, please contact an IEI sales representative.

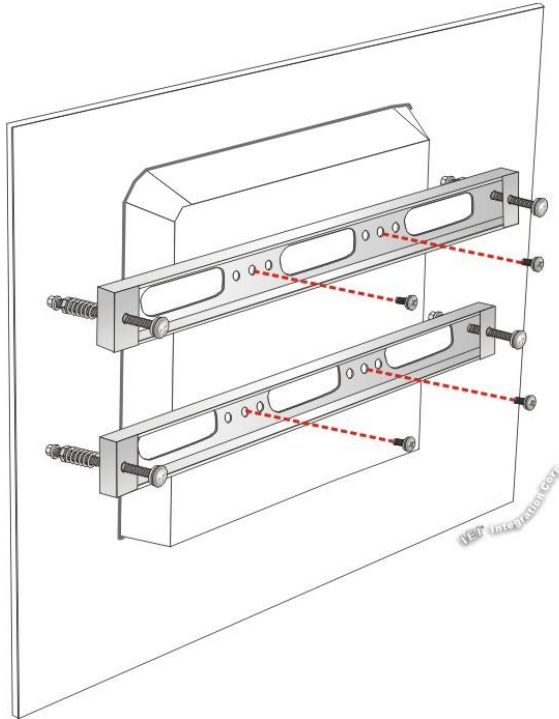

Figure 3-13: Securing Panel Mounting Brackets

3.8.3 Cabinet and Rack Installation

The AFL3-W07A-AL2 flat bezel panel PC can be installed into a cabinet or rack. The installation procedures are similar to the panel mounting installation. To do this, please follow the steps below:



NOTE:

When purchasing the cabinet/rack installation bracket, make sure it is compatible with both the AFL3-W07A-AL2 flat bezel panel PC and the rack/cabinet into which the AFL3-W07A-AL2 is installed.

- Step 1:** Slide the rear chassis of the AFL3-W07A-AL2 flat bezel panel PC through the rack/cabinet bracket until the frame is flush against the front of the bracket (Figure 3-14).

AFL3-W07A-AL2 Panel PC

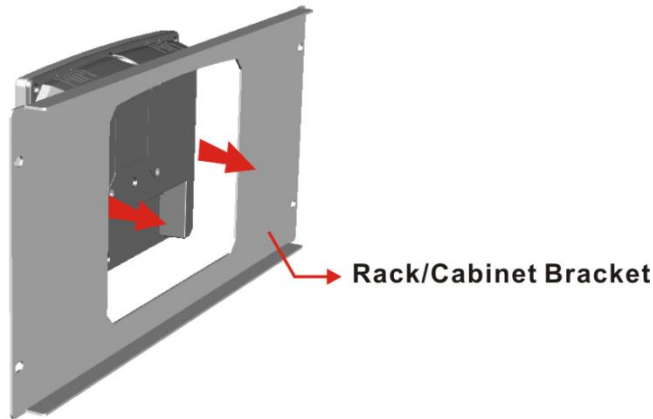





Figure 3-14: Rack/Cabinet Bracket Installation

Step 2: Insert a M5*50 screw into the screw hole on the side of the rack mounting bracket. Then, install the following components onto the screw in sequence.

See **Figure 3-15**.

Sequence	Item	Photo	Instruction
1	Spring		Install a spring onto the screw.
2	Nut		Tighten a nut until the spring is compressed enough for plastic cap.
3	Plastic cap		Tighten a plastic cap onto the end of screw thread.

Step 3: Repeat **Step 4** to install the other three screws into the sides of the two rack mounting brackets.

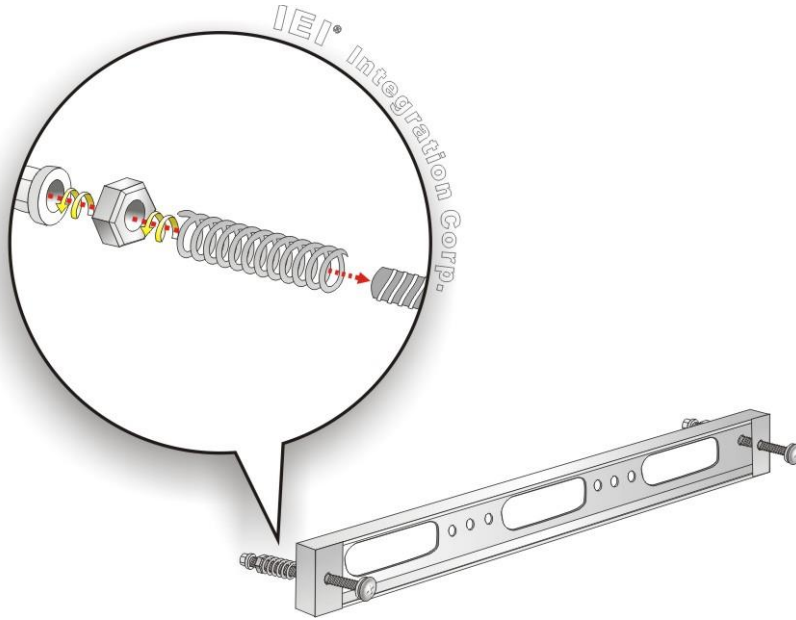

Figure 3-15: Rack Mounting Kit Installation

- Step 4:** Align the rack mounting bracket screw holes with the VESA mounting holes on the rear of the panel PC.
- Step 5:** Secure the two rack mounting brackets to the rear of the panel PC by inserting the four retention screws into the VESA mounting holes and tightening them (Figure 3-16).



NOTE:

The rack mounting kit described in this section is an optional item. To purchase it, please contact an IEI sales representative.

AFL3-W07A-AL2 Panel PC

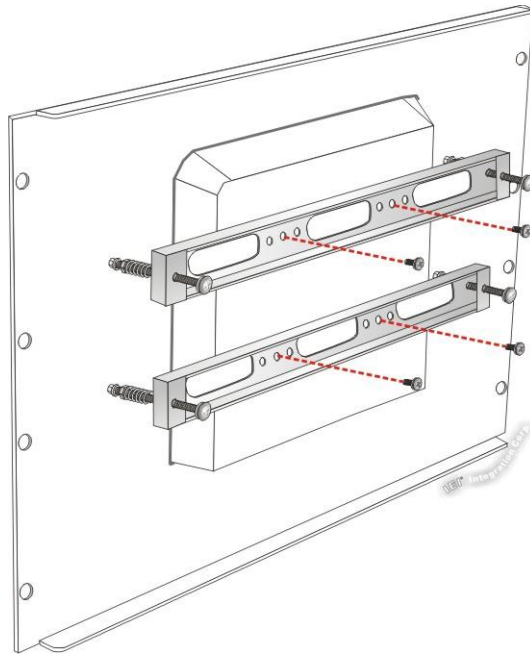

Figure 3-16: Securing Rack Mounting Brackets

Step 6: Slide the panel PC with the attached rack/cabinet bracket into a rack or cabinet (Figure 3-17).

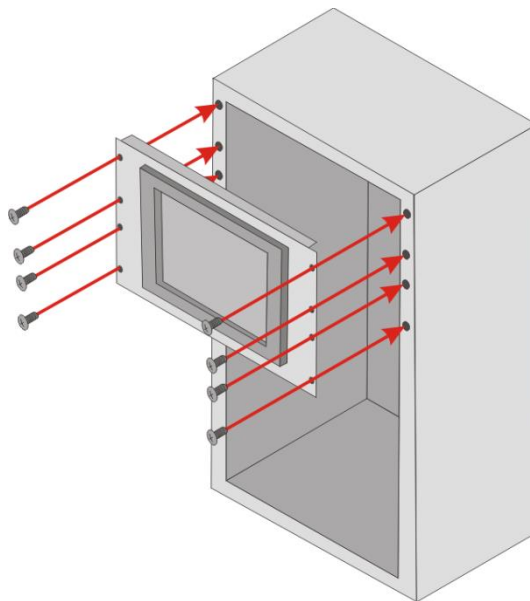

Figure 3-17: Install into a Rack/Cabinet

Step 7: Once the panel PC with the attached rack/cabinet bracket has been properly inserted into the rack or cabinet, secure the front of the rack/cabinet bracket to the front of the rack or cabinet (**Figure 3-17**).

3.8.4 Arm Mounting

The AFL3-W07A-AL2 is VESA (Video Electronics Standards Association) compliant and can be mounted on an arm with a 75 mm interface pad. To mount the AFL3-W07A-AL2 on an arm, please follow the steps below.

Step 1: The arm is a separately purchased item. Please correctly mount the arm onto the surface it uses as a base. To do this, refer to the installation documentation that came with the mounting arm.



NOTE:

When purchasing the arm please ensure that it is VESA compliant and that the arm has a 75 mm interface pad. If the mounting arm is not VESA compliant it cannot be used to support the AFL3-W07A-AL2 flat bezel panel PC.

Step 2: Once the mounting arm has been firmly attached to the surface, lift the flat bezel panel PC onto the interface pad of the mounting arm.

Step 3: Align the retention screw holes on the mounting arm interface with those in the flat bezel panel PC (**Figure 3-18**).

AFL3-W07A-AL2 Panel PC



Figure 3-18: Arm Mounting Retention Screw Holes

Step 4: Secure the AFL3-W07A-AL2 to the interface pad by inserting four retention screws through the mounting arm interface pad and into the AFL3-W07A-AL2.

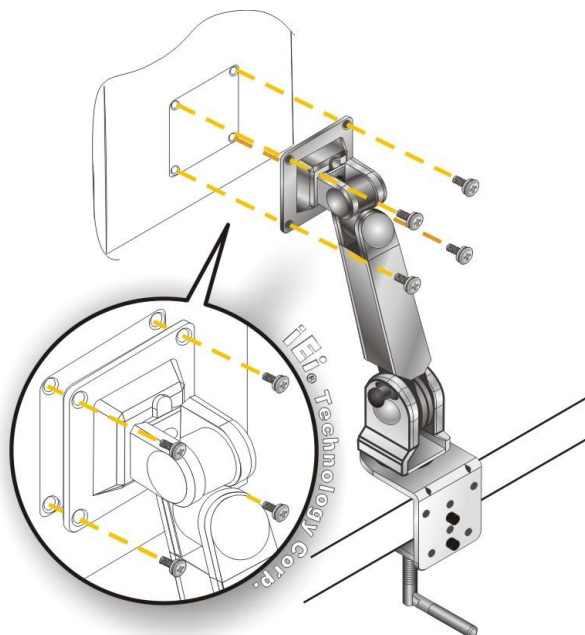

Figure 3-19: Arm Mounting

3.8.5 Stand Mounting

To mount the AFL3-W07A-AL2 using the stand mounting kit, please follow the steps below.

Step 1: Locate the screw holes on the rear of the AFL3-W07A-AL2. This is where the bracket will be attached.

Step 2: Align the bracket with the screw holes.

Step 3: To secure the bracket to the AFL3-W07A-AL2 insert the retention screws into the screw holes and tighten them.

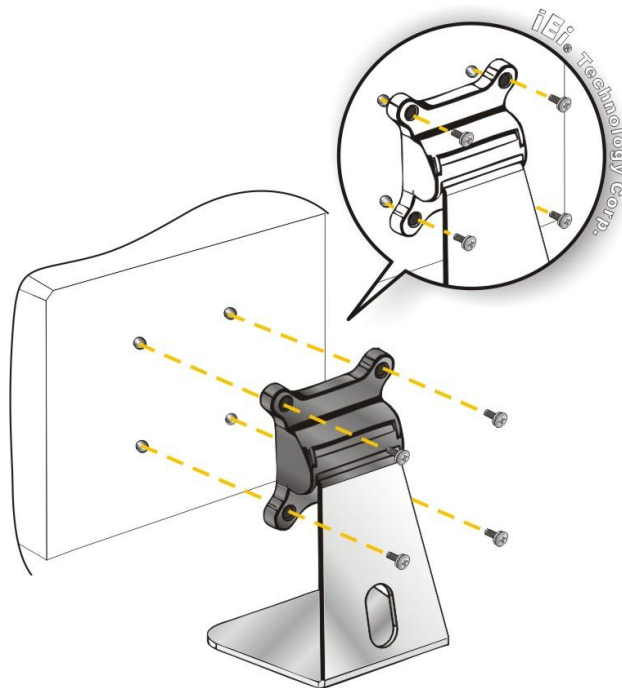

Figure 3-20: Stand Mounting (Stand-A/Bxx)

AFL3-W07A-AL2 Panel PC

3.8.6 V-Stand Mounting

To mount the AFL3-W07A-AL2 using the V-Stand mounting kit, please follow the steps below.

Step 1: Carefully mark the locations of the four V-Stand screw holes on the mounting area. Drill four pilot holes at the marked locations for the V-Stand retention screws.

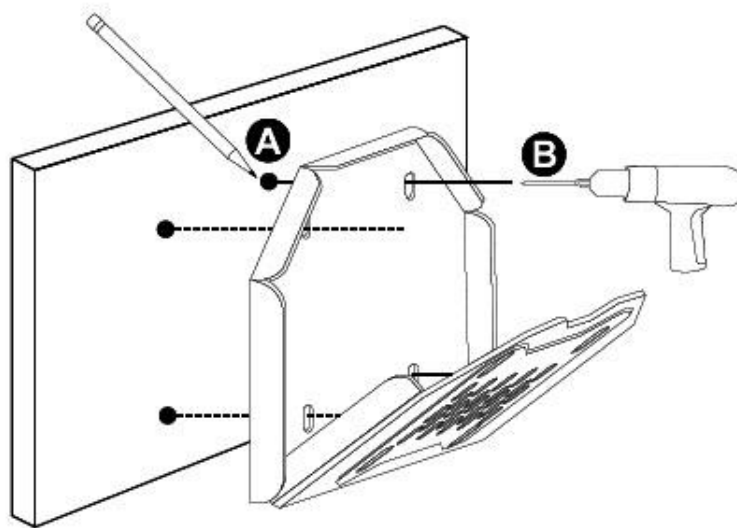

Figure 3-21: Drill Pilot Holes for V-Stand

- Step 2:** Align the screw holes on the V-Stand with the VESA mount screw holes on the system rear panel.
- Step 3:** Insert the four VESA mount screws into the four screw holes on the system rear panel. Adjust the V-Stand to a proper position.
- Step 4:** Tighten until the screw shank is secured against the rear panel.

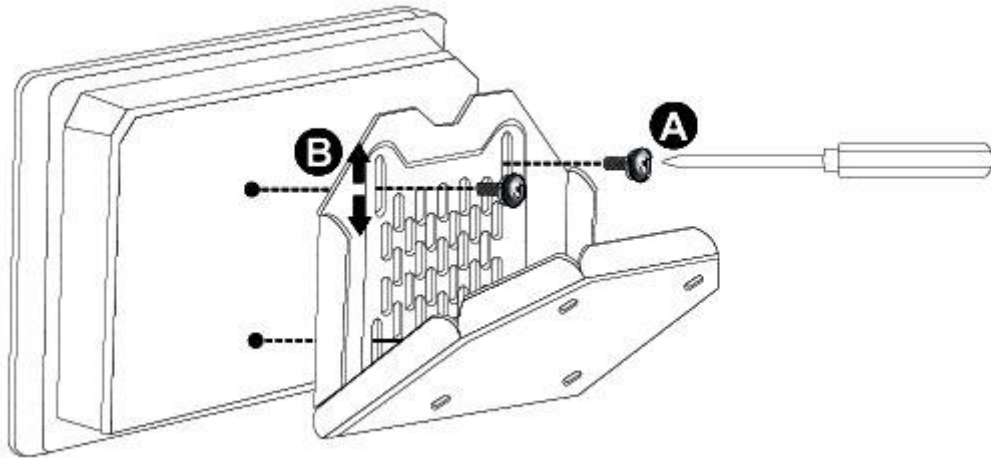

Figure 3-22: Secure V-Stand to System

Step 5: Align the V-Stand screw holes with the pilot holes on the mounting area. Mount the V-Stand by inserting the retention screws into the four pilot holes and tightening them.

Step 6: Adjust the V-Stand to have a best viewing angle to operate the system.

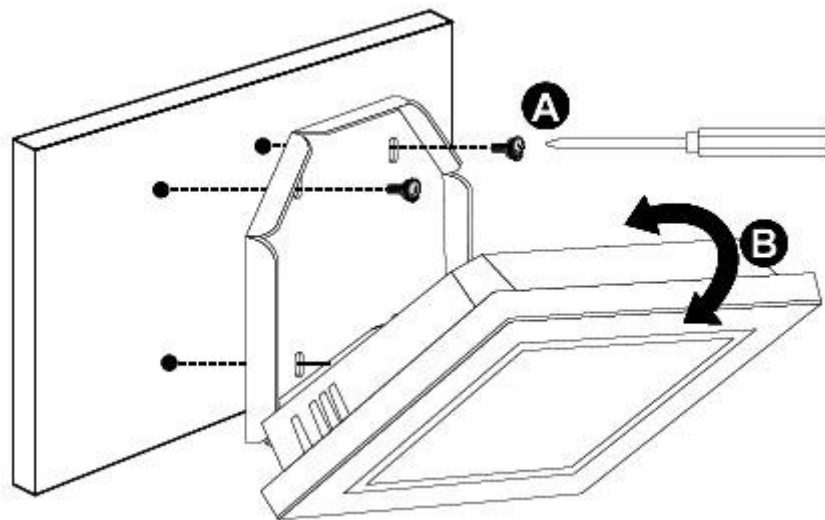

Figure 3-23: Secure V-Stand to Mounting Area

AFL3-W07A-AL2 Panel PC

3.9 Powering On the System

To power on the system, follow the steps below:

- Step 1:** Connect the power cord to the power adapter. Connect the other end of the power cord to a power source. **Ensure to connect the power cord to a socket-outlet with earthing connection.**
- Step 2:** Connect the power adapter to the power connector of the AFL3-W07A-AL2.
- Step 3:** Locate the power button on the I/O panel.
- Step 4:** Hold down the power button until the power LED on the front panel turns on in green.



Figure 3-24: Powering On the System



NOTE:

When both DC-in and PoE are connected to the device, the DC-in will be used as the main power source. Disconnecting DC-in while the system is running may lead to system shutdown or reboot.

To switch to the PoE mode, shut down the system, disconnect DC-in, and provide power through the PoE port.

3.10 Reset the System

The reset button enables user to reboot the system when the system is turned on. The reset button location is shown in **Figure 3-25**. Press the reset button to reboot the system.



Figure 3-25: Reset Button Location

AFL3-W07A-AL2 Panel PC

3.11 Clear CMOS

If the AFL3-W07A-AL2 fails to boot due to improper BIOS settings, the clear CMOS button clears the CMOS data and resets the system BIOS information. To do this, push the clear CMOS button for three seconds, then restart the system. The clear CMOS button location is shown in **Figure 3-26**.



Figure 3-26: Clear CMOS Button Location

3.12 Software Installation

All the drivers for the AFL3-W07A-AL2 are available on IEI Resource Download Center (<https://download.ieiworld.com>). Type AFL3-W07A-AL2 and press Enter to find all the relevant software, utilities, and documentation.

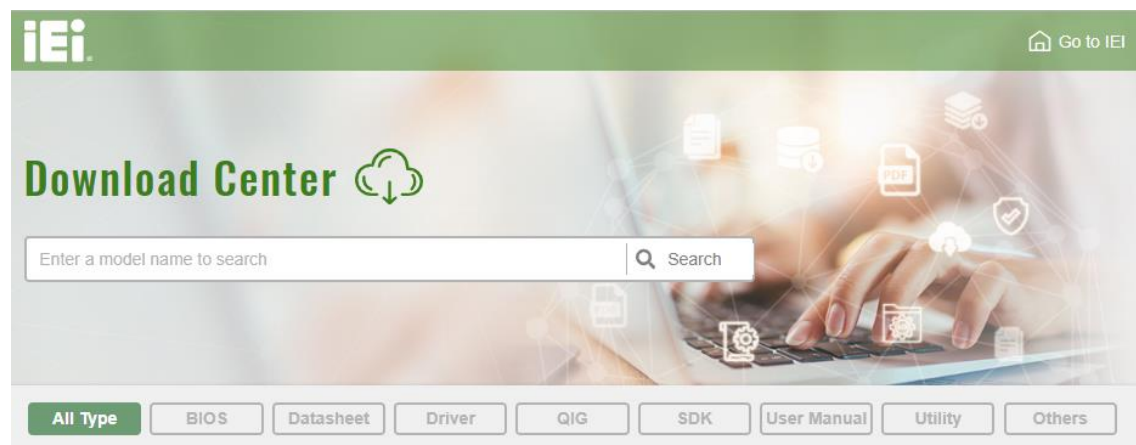
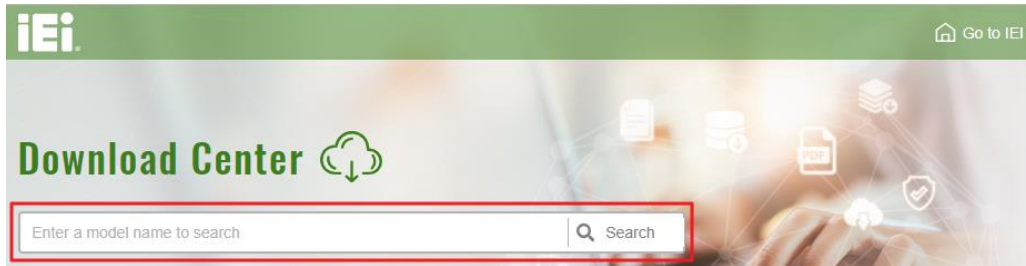

Figure 3-27: IEI Resource Download Center

3.12.1 Driver Download

To download drivers from IEI Resource Download Center, follow the steps below.

Step 1: Go to <https://download.ieiworld.com>. Type AFL3-W07A-AL2 and press Enter.



Step 2: All product-related software, utilities, and documentation will be listed. You can choose **Driver** to filter the result.

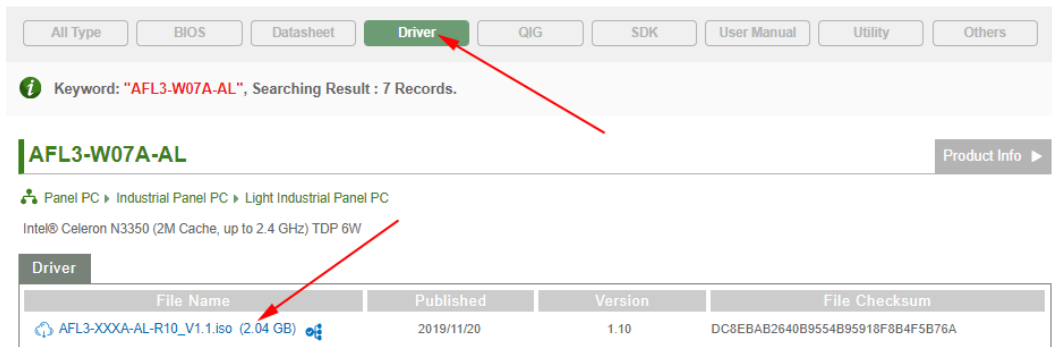

Step 3: Click the driver file name on the page and you will be prompted with the following window. You can download the entire ISO file (❶), or click the small arrow to find an individual driver and click the file name to download (❷).

AFL3-W07A-AL2 Panel PC

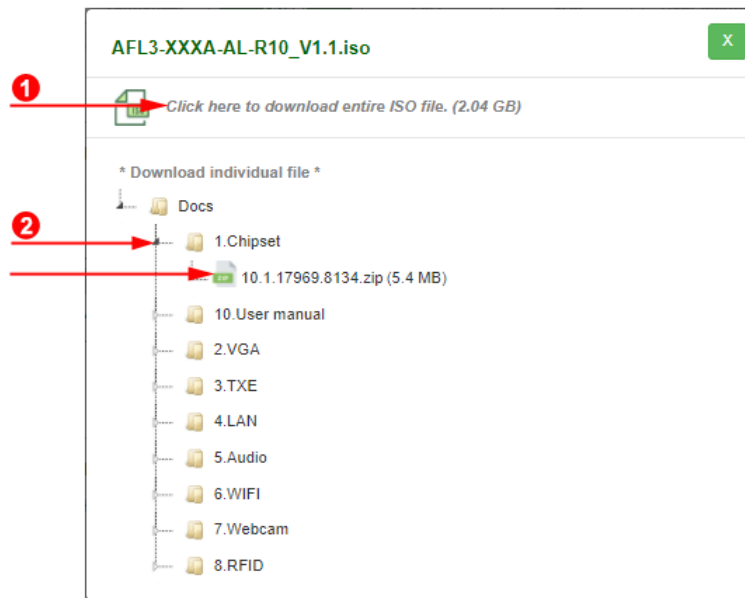

NOTE:

To install software from the downloaded ISO image file in Windows 8 (or later), double-click the ISO file to mount it as a virtual drive to view its content.

Chapter

4

BIOS Setup

AFL3-W07A-AL2 Panel PC

4.1 Introduction

A licensed copy of the BIOS is preprogrammed into the ROM BIOS. The BIOS setup program allows users to modify the basic system configuration. This chapter describes how to access the BIOS setup program and the configuration options that may be changed.



NOTE:

Some of the BIOS options may vary throughout the life cycle of the product and are subject to change without prior notice.

4.1.1 Starting Setup

The UEFI BIOS is activated when the computer is turned on. The setup program can be activated in one of two ways.

1. Press the **DEL** key as soon as the system is turned on or
2. Press the **DEL** key when the “**Press DEL to enter SETUP**” message appears on the screen.

If the message disappears before the **DEL** key is pressed, restart the computer and try again.

4.1.2 Using Setup

Use the arrow keys to highlight items, press **ENTER** to select, use the PageUp and PageDown keys to change entries, press **F1** for help and press **ESC** to quit. Navigation keys are shown in the following table.

Key	Function
Up arrow	Move to the item above
Down arrow	Move to the item below
Left arrow	Move to the item on the left hand side

Right arrow	Move to the item on the right hand side
+	Increase the numeric value or make changes
-	Decrease the numeric value or make changes
F1 key	General help, only for Status Page Setup Menu and Option Page Setup Menu
F2 key	Load previous values.
F3 key	Load optimized defaults
F4 key	Save changes and Exit BIOS
Esc key	Main Menu – Quit and do not save changes into CMOS Status Page Setup Menu and Option Page Setup Menu -- Exit current page and return to Main Menu

Table 6-1: BIOS Navigation Keys

4.1.3 Getting Help

When **F1** is pressed a small help window describing the appropriate keys to use and the possible selections for the highlighted item appears. To exit the Help Window press **Esc** or the **F1** key again.

4.1.4 Unable to Reboot after Configuration Changes

If the computer cannot boot after changes to the system configuration are made, CMOS defaults. Use the clear CMOS button described in **Section 3.11**.

4.1.5 BIOS Menu Bar

The **menu bar** on top of the BIOS screen has the following main items:

- Main – Changes the basic system configuration.
- Advanced – Changes the advanced system settings.
- Chipset – Changes the chipset settings.
- Security – Sets User and Supervisor Passwords.
- Boot – Changes the system boot configuration.
- Save & Exit – Selects exit options and loads default settings

The following sections completely describe the configuration options found in the menu items at the top of the BIOS screen and listed above.

AFL3-W07A-AL2 Panel PC

4.2 Main

The **Main** BIOS menu (**BIOS Menu 1**) appears when the **BIOS Setup** program is entered. The **Main** menu gives an overview of the basic system information.

```

Aptio Setup Utility - Copyright (C) 2020 American Megatrends, Inc.
Main  Advanced  Chipset  Security  Boot  Save & Exit

BIOS Information
BIOS Vendor          American Megatrends
Core Version         5.12
Compliancy           UEFI 2.5; PI 1.4
Project Version      Z677AR10.ROM
Build Date and Time  09/21/2020 13:53:17

iWDD Vendor          iEi
iWDD Version         Z677ER10.bin

Platform firmware Information
BXT SOC              F1
MRC Version          0.56
PUNIT FW             1E
PMC FW               03.21
TXE FW               3.1.76.2356
ISH FW               4.1.0.3364
GOP                  0.0.0036

Memory Information
Total Memory         4096 MB
Memory Speed         1600 MHz

Access Level          Administrator

System Date          [Wed 01/02/2020]
System Time          [14:26:28]

Set the Date. Use Tab to
switch between Data
elements.

-----
<=>: Select Screen
↑ ↓: Select Item
EnterSelect
+/-: Change Opt.
F1: General Help
F2: Previous Values
F3: Optimized Defaults
F4: Save & Exit
ESC: Exit

Version 2.18.1263. Copyright (C) 2020 American Megatrends, Inc.
  
```

BIOS Menu 1: Main

→ System Date [xx/xx/xx]

Use the **System Date** option to set the system date. Manually enter the day, month and year.

→ **System Time [xx:xx:xx]**

Use the **System Time** option to set the system time. Manually enter the hours, minutes and seconds.

4.3 Advanced

Use the **Advanced** menu (**BIOS Menu 2**) to configure the CPU and peripheral devices through the following sub-menus:



WARNING:

Setting the wrong values in the sections below may cause the system to malfunction. Make sure that the settings made are compatible with the hardware.

```

Aptio Setup Utility - Copyright (C) 2020 American Megatrends, Inc.
Main  Advanced  Chipset  Security  Boot  Save & Exit

> ACPI Settings                System ACPI Parameters.
> F81216 Super IO Configuration
> iWDD H/M Monitor
> USB Configuration
> CPU Configuration
> RTC Wake Settings
> Power Saving Configuration
> Serial Port Console Redirection
> iEi Feature

-----
<=>: Select Screen
↑ ↓: Select Item
Enter>Select
+/-: Change Opt.
F1: General Help
F2: Previous Values
F3: Optimized Defaults
F4: Save & Exit
ESC: Exit

Version 2.18.1263. Copyright (C) 2020 American Megatrends, Inc.
    
```

BIOS Menu 2: Advanced

AFL3-W07A-AL2 Panel PC

4.3.1 ACPI Settings

The **ACPI Settings** menu (**BIOS Menu 3**) configures the Advanced Configuration and Power Interface (ACPI) options.

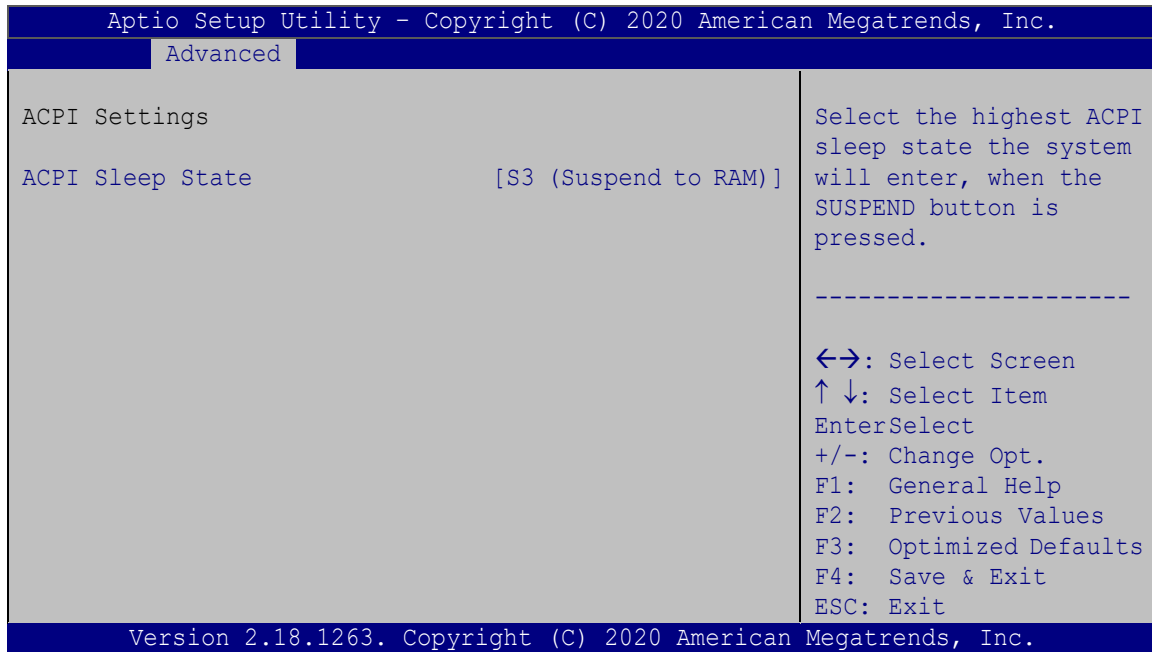

BIOS Menu 3: ACPI Settings

→ ACPI Sleep State [S3 (Suspend to RAM)]

Use the **ACPI Sleep State** option to specify the sleep state the system enters when it is not being used.

- **S3 (Suspend to DEFAULT RAM)** The caches are flushed and the CPU is powered off. Power to the RAM is maintained. The computer returns slower to a working state, but more power is saved.

4.3.2 F81216 Super IO Configuration

Use the **F81216 Super IO Configuration** menu (**BIOS Menu 4**) to set or change the configurations for the serial port.

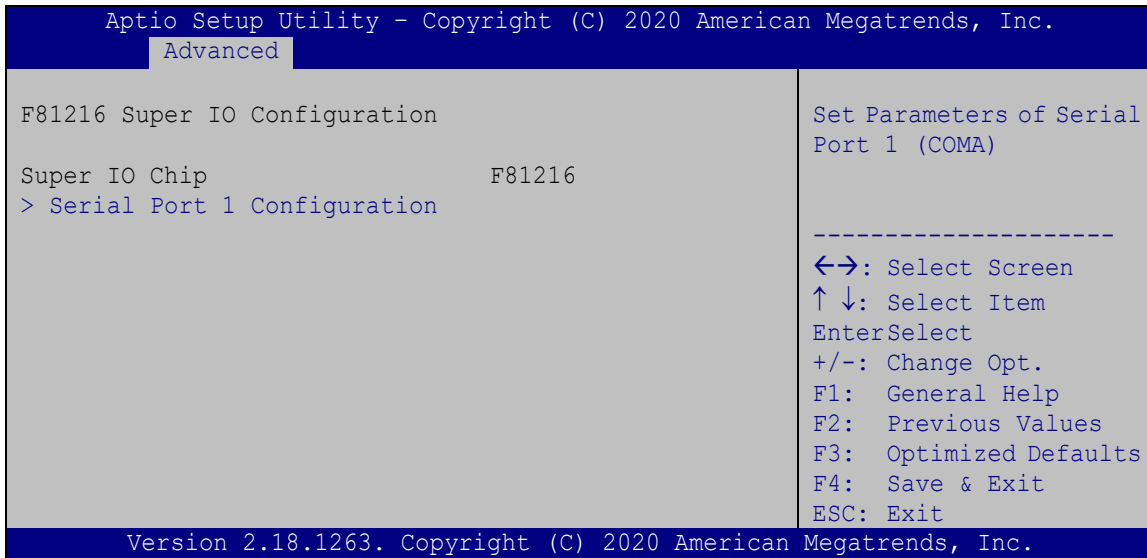

BIOS Menu 4: F81216 Super IO Configuration

4.3.2.1 Serial Port 1 Configuration

Use the **Serial Port 1 Configuration** menu (**BIOS Menu 5**) to configure the serial port.

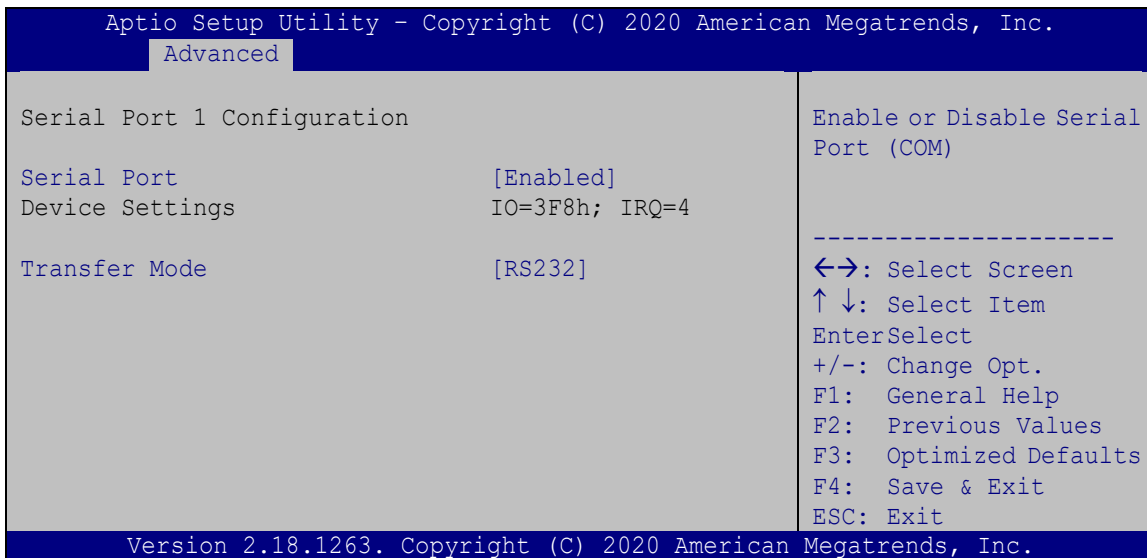

BIOS Menu 5: Serial Port n Configuration Menu

AFL3-W07A-AL2 Panel PC

→ Serial Port [Enabled]

Use the **Serial Port** option to enable or disable the serial port.

- **Disabled** Disable the serial port
- **Enabled** **DEFAULT** Enable the serial port

→ Transfer Mode [RS232]

Use the **Transfer Mode** option to select the Serial Port signaling mode.

- **RS422** Serial Port 1 signaling mode is RS-422
- **RS485** Serial Port 1 signaling mode is RS-485
- **RS232** **DEFAULT** Serial Port 1 signaling mode is RS-232

4.3.3 iWDD H/W Monitor

The iWDD H/W Monitor menu (**BIOS Menu 6**) shows the operating temperatures and voltages.

```

Aptio Setup Utility - Copyright (C) 2020 American Megatrends, Inc.
-----
Advanced
-----
PC Health Status
System temperature           :+33 °C

CPU_CORE                    :+0.741 V
+5V                          :+4.991 V
+12V                        :+11.645 V
+DDR                         :+1.348 V
+5VSB                       :+5.005 V
+3.3V                       :+3.281 V
+3.3VSB                     :+3.311 V

-----
<->: Select Screen
↑ ↓: Select Item
Enter>Select
+/-: Change Opt.
F1:  General Help
F2:  Previous Values
F3:  Optimized Defaults
F4:  Save & Exit
ESC: Exit
-----
Version 2.18.1263. Copyright (C) 2020 American Megatrends, Inc.
  
```

BIOS Menu 6: iWDD H/W Monitor

➔ **Hardware Health Status**

The following system parameters and values are shown. The system parameters that are monitored are:

- System Temperature
- Voltages:
 - CPU_CORE
 - +5V
 - +12V
 - +DDR
 - +5VSB
 - +3.3V
 - +3.3VSB

4.3.4 USB Configuration

Use the **USB Configuration** menu (**BIOS Menu 7**) to read USB configuration information and configure the USB settings.

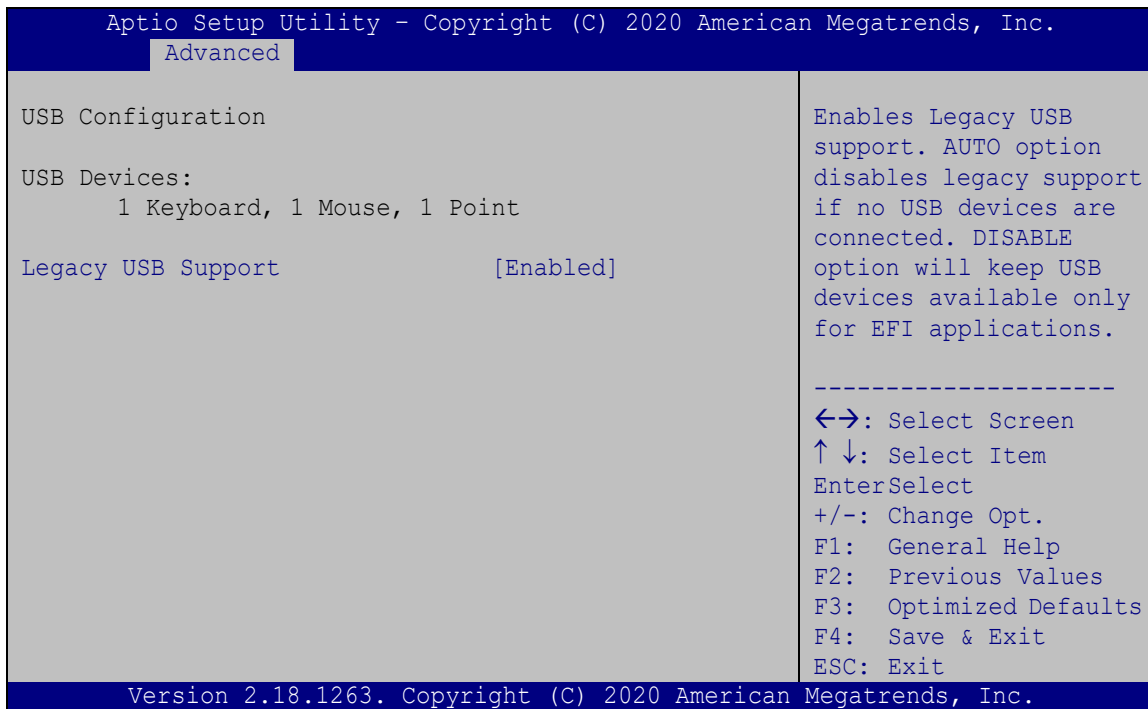

BIOS Menu 7: USB Configuration

AFL3-W07A-AL2 Panel PC

→ USB Devices

The **USB Devices Enabled** field lists the USB devices that are enabled on the system

→ Legacy USB Support [Enabled]

Use the **Legacy USB Support** BIOS option to enable USB mouse and USB keyboard support. Normally if this option is not enabled, any attached USB mouse or USB keyboard does not become available until a USB compatible operating system is fully booted with all USB drivers loaded. When this option is enabled, any attached USB mouse or USB keyboard can control the system even when there is no USB driver loaded onto the system.

- | | | |
|-------------------|----------------|---|
| → Enabled | DEFAULT | Legacy USB support enabled |
| → Disabled | | Legacy USB support disabled |
| → Auto | | Legacy USB support disabled if no USB devices are connected |

4.3.5 CPU Configuration

Use the **CPU Configuration (BIOS Menu 8)** to view detailed CPU specifications and configure the CPU.

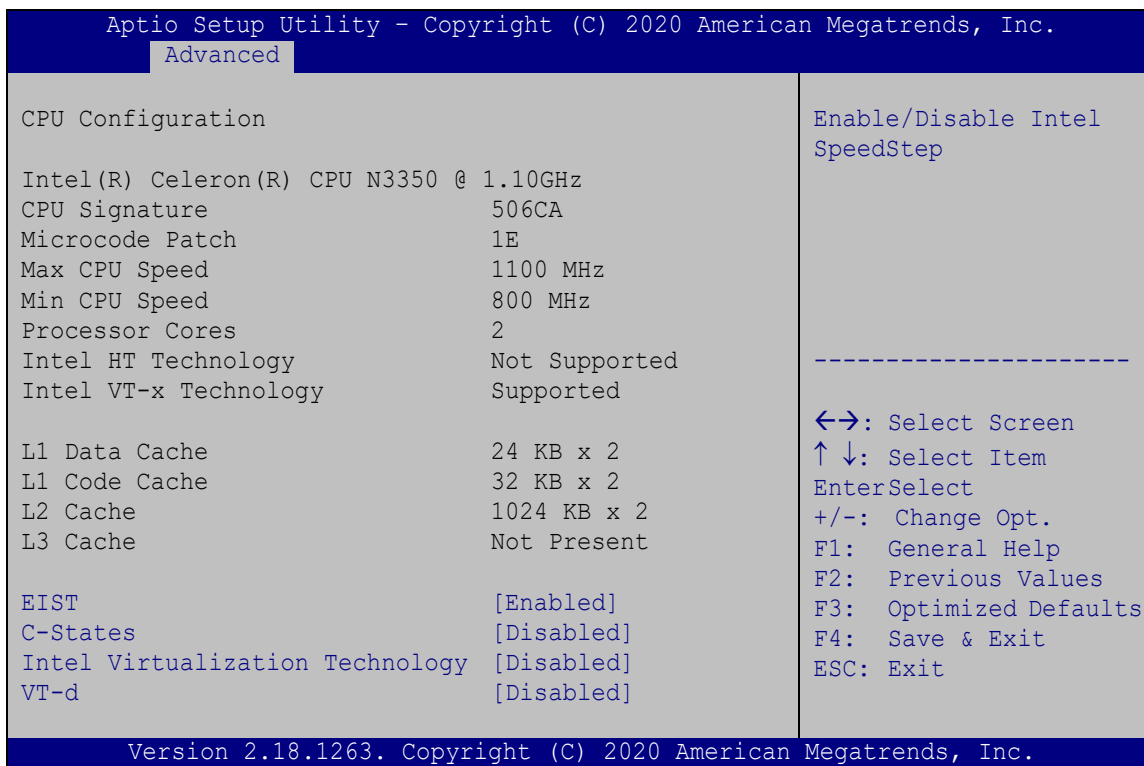

BIOS Menu 8: CPU Configuration

→ EIST [Enabled]

Use the **EIST** option to enable or disable the Intel® Speed Step Technology.

- **Disabled** Disables the Intel® Speed Step Technology.
- **Enabled** **DEFAULT** Enables the Intel® Speed Step Technology.

→ C-States [Disabled]

Use the **C-States** option to enable or disable the C-states.

- **Disabled** **DEFAULT** Disables the C-state
- **Enabled** Enables the C-state

AFL3-W07A-AL2 Panel PC

→ Intel Virtualization Technology [Disabled]

Use the **Intel Virtualization Technology** option to enable or disable virtualization on the system. When combined with third party software, Intel® Virtualization technology allows several OSs to run on the same system at the same time.

→ **Disabled** **DEFAULT** Disables Intel® Virtualization Technology.

→ **Enabled** Enables Intel® Virtualization Technology.

→ VT-d [Disabled]

Use the **VT-d** BIOS option to enable or disabled VT-d support.

→ **Disabled** **DEFAULT** Disable VT-d support.

→ **Enabled** Enable VT-d support.

4.3.6 RTC Wake Settings

The **RTC Wake Settings** menu (**BIOS Menu 9**) configures RTC wake event.

```

Aptio Setup Utility - Copyright (C) 2020 American Megatrends, Inc.
  Advanced
RTC Wake Settings
Wake system with Fixed Time      [Disabled]
Enable or disable System
wake on alarm event. When
enabled, System will wake
on the dat::hr::min::sec
specified
-----
←→: Select Screen
↑ ↓: Select Item
Enter>Select
F1  General Help
F2  Previous Values
F3  Optimized Defaults
F4  Save
ESC Exit
Version 2.18.1263. Copyright (C) 2020 American Megatrends, Inc.
  
```

BIOS Menu 9: RTC Wake Settings

➔ **Wake System with Fixed Time [Disabled]**

Use the **Wake System with Fixed Time** option to specify the time the system should be roused from a suspended state.

- ➔ **Disabled** **DEFAULT** The real time clock (RTC) cannot generate a wake event
- ➔ **Enabled** If selected, the following appears with values that can be selected:
 - *Wake up every day
 - *Wake up date
 - *Wake up hour
 - *Wake up minute
 - *Wake up second
 After setting the alarm, the computer turns itself on from a suspend state when the alarm goes off.

4.3.7 Power Saving Configuration

Use the **Power Saving Configuration** menu (**BIOS Menu 10**) to configure system to reduce power consumption in system off state.

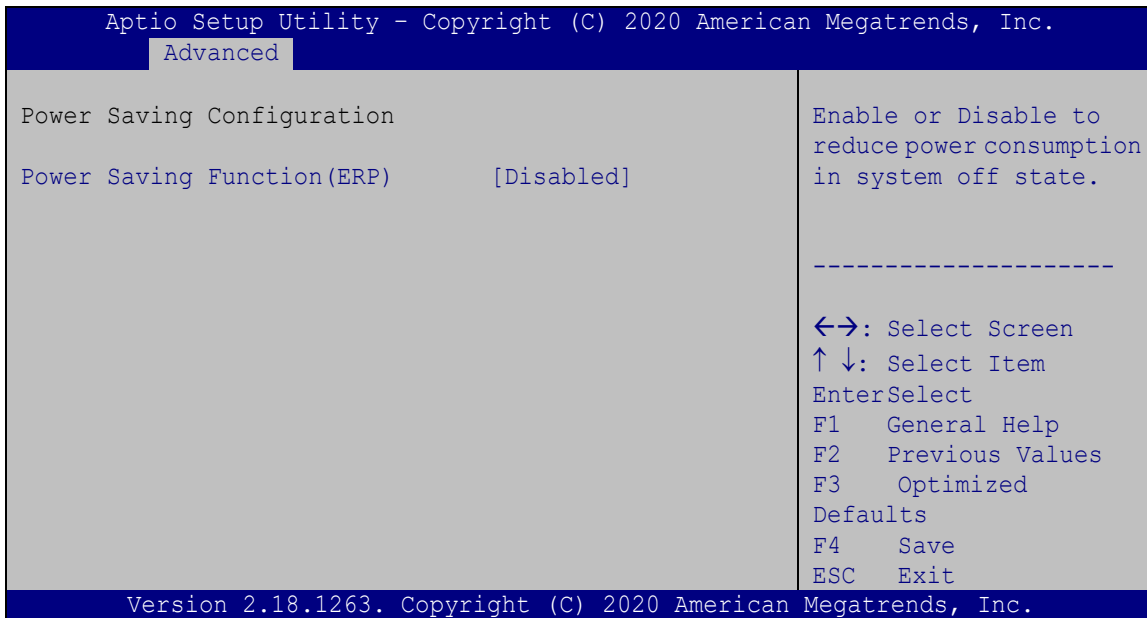

BIOS Menu 10: Power Saving Configuration

AFL3-W07A-AL2 Panel PC

→ Power Saving Function(ERP) [Disabled]

Use the **Power Saving Function** BIOS option to enable or disable the power saving function.

- **Disabled** **DEFAULT** Power saving function is disabled.
- **Enabled** Power saving function is enabled. It will reduce power consumption when the system is off.

4.3.8 Serial Port Console Redirection

The **Serial Port Console Redirection** menu (**BIOS Menu 11**) allows the console redirection options to be configured. Console redirection allows users to maintain a system remotely by re-directing keyboard input and text output through the serial port.

```

Aptio Setup Utility - Copyright (C) 2020 American Megatrends, Inc.
  Advanced
COM1
  Console Redirection                      [Disabled]
> Console Redirection Settings

  Legacy Console Redirection
> Legacy Console Redirection Settings

  Console Redirection
  Enable or Disable.

-----
<->: Select Screen
↑ ↓: Select Item
EnterSelect
+/-: Change Opt.
F1: General Help
F2: Previous Values
F3: Optimized Defaults
F4: Save & Exit
ESC: Exit

Version 2.18.1263. Copyright (C) 2020 American Megatrends, Inc.
  
```

BIOS Menu 11: Serial Port Console Redirection

→ Console Redirection [Disabled]

Use **Console Redirection** option to enable or disable the console redirection function.

- **Disabled** **DEFAULT** Disabled the console redirection function
- **Enabled** Enabled the console redirection function

4.3.8.1 Legacy Console Redirection Settings

The **Legacy Console Redirection Settings** menu (**BIOS Menu 12**) allows the legacy console redirection options to be configured.

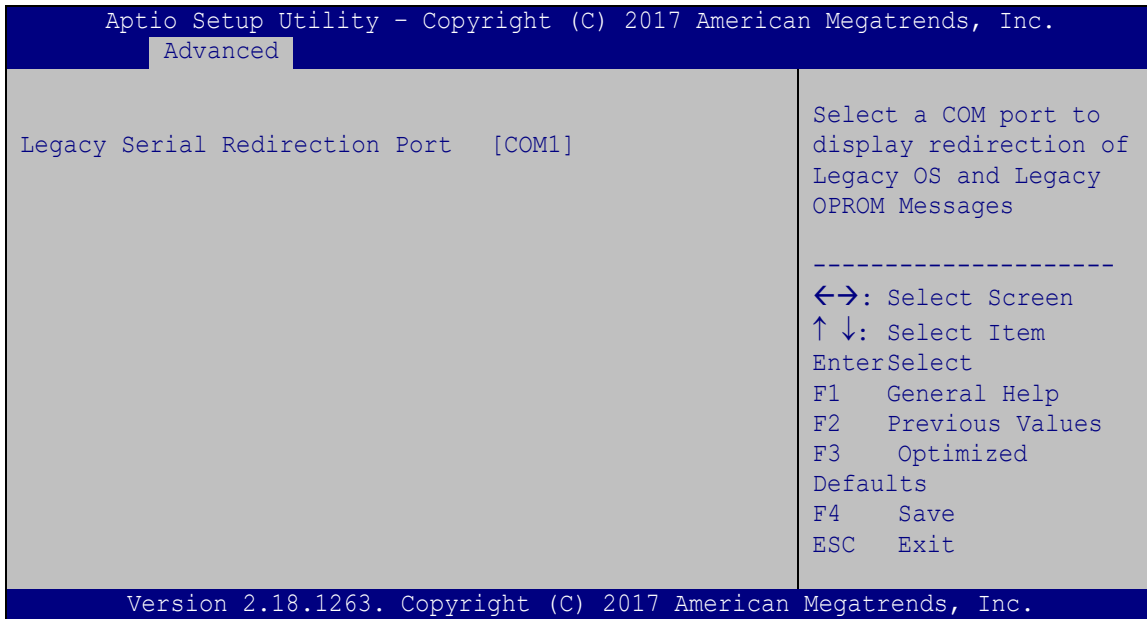

BIOS Menu 12: Legacy Console Redirection Settings

→ Legacy Serial Redirection Port [COM1]

Use the **Legacy Serial Redirection Port** option to specify a COM port to display redirection of legacy OS and legacy OPROM messages. The options include:

- COM1 **DEFAULT**

AFL3-W07A-AL2 Panel PC

4.3.9 IEI Feature

Use the **IEI Feature** menu (**BIOS Menu 13**) to configure One Key Recovery function.

```

Aptio Setup Utility - Copyright (C) 2020 American Megatrends, Inc.
  Advanced
iEi Feature
Auto Recovery Function          [Disabled]
Auto Recovery Function          Auto Recovery Function
                                Reboot and recover
                                system automatically
                                within 10 min, when OS
                                crashes. Please install
                                Auto Recovery API
                                service before enabling
                                this function.
                                -----
                                →←: Select Screen
                                ↑ ↓: Select Item
                                Enter: Select
                                +/-: Change Opt.
                                F1:  General Help
                                F2:  Previous Values
                                F3:  Optimized Defaults
                                F4:  Save & Exit
                                ESC: Exit
Version 2.18.1263. Copyright (C) 2020 American Megatrends, Inc.

```

BIOS Menu 13: IEI Feature

→ Auto Recovery Function [Disabled]

Use the **Auto Recovery Function** BIOS option to enable or disable the auto recovery function of the IEI One Key Recovery.

- **Disabled** **DEFAULT** Auto recovery function disabled
- **Enabled** Auto recovery function enabled

4.4 Chipset

Use the **Chipset** menu (**BIOS Menu 14**) to access the North Bridge, South Bridge, and Integrated Graphics configuration menus.



WARNING!

Setting the wrong values for the Chipset BIOS selections in the Chipset BIOS menu may cause the system to malfunction.

```
Aptio Setup Utility - Copyright (C) 2020 American Megatrends, Inc.
Main   Advanced  Chipset  Security  Boot   Save & Exit
-----
> North Bridge
> South Bridge

North Bridge Parameters
-----
<=>: Select Screen
↑↓: Select Item
Enter>Select
+ - Change Opt.
F1  General Help
F2  Previous Values
F3  Optimized Defaults
F4  Save & Exit
ESC Exit

Version 2.18.1263. Copyright (C) 2020 American Megatrends, Inc.
```

BIOS Menu 14: Chipset

AFL3-W07A-AL2 Panel PC

4.4.1 North Bridge Configuration

Use the **North Bridge** menu (**BIOS Menu 15**) to configure the north bridge chipset.

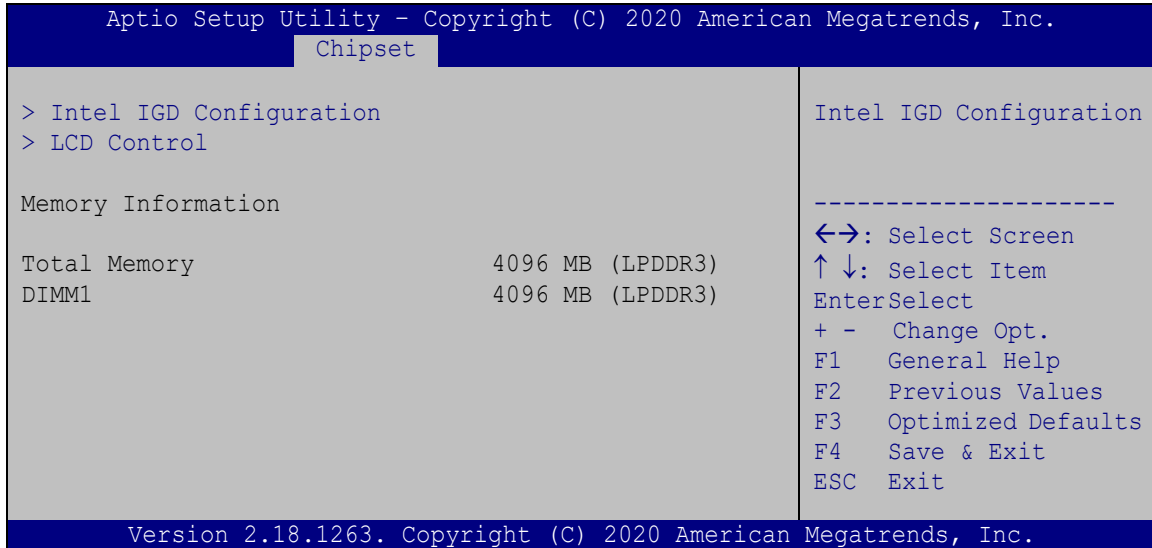

BIOS Menu 15: North Bridge Configuration

4.4.1.1 Internal IGD Configuration

Use the Internal IGD Configuration (**BIOS Menu 16**) menu to set the integrated graphics.

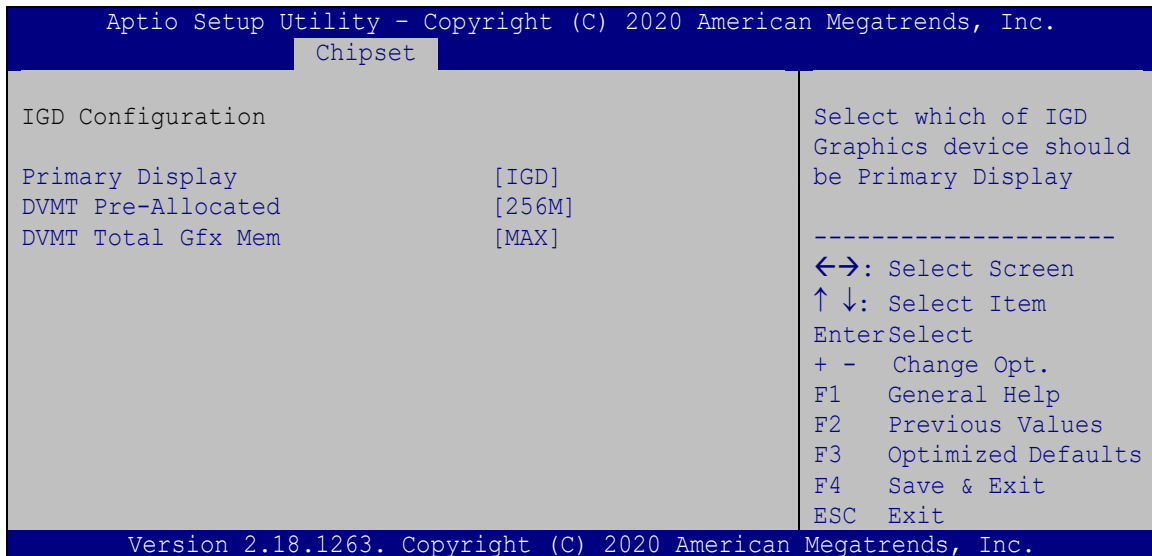

BIOS Menu 16: Internal IGD Configuration

→ Primary Display [IGD]

Use the **Primary Display** option to select the graphics controller used as the primary boot device. Configuration option is listed below:

- IGD **DEFAULT**

→ DVMT Pre-Allocated [256M]

Use the **DVMT Pre-Allocated** option to set the amount of system memory allocated to the integrated graphics processor when the system boots. The system memory allocated can then only be used as graphics memory, and is no longer available to applications or the operating system. Configuration options are listed below:

- 64M
- 128M
- 256M **DEFAULT**
- 512M

→ DVMT Total Gfx Mem [MAX]

Use the **DVMT Total Gfx Mem** option to select DVMT5.0 total graphic memory size used by the internal graphic device. The following options are available:

- 128M
- 256M
- MAX **DEFAULT**

AFL3-W07A-AL2 Panel PC

4.4.1.2 LCD Control

Use the **LCD Control** submenu (**BIOS Menu 17**) to select a display device which will be activated during POST.

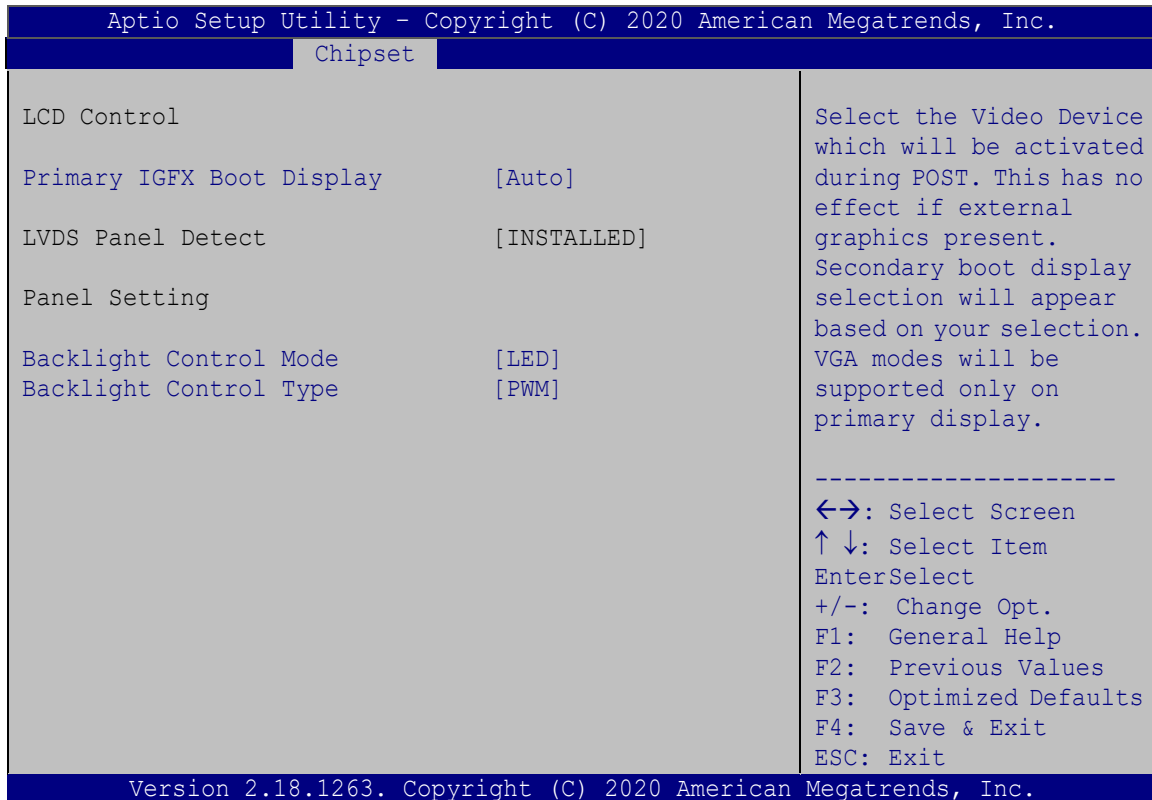

BIOS Menu 17: LCD Control

→ Primary IGFX Boot Display [Auto]

Use the **Primary IGFX Boot Display** option to select the display device used by the system when it boots.

- Auto **DEFAULT**
- LVDS2
- HDMI1

➔ **Backlight Control Mode [LED]**

Use the **Backlight Control Mode** option to specify the backlight control mode. Configuration option is listed below.

- LED **DEFAULT**

➔ **Backlight Control Type [PWM]**

Use the **Backlight Control Type** option to specify the backlight control type. Configuration option is listed below.

- PWM **DEFAULT**

4.4.2 South Bridge Configuration

Use the **South Bridge Configuration** menu (**BIOS Menu 18**) to configure the south bridge chipset.

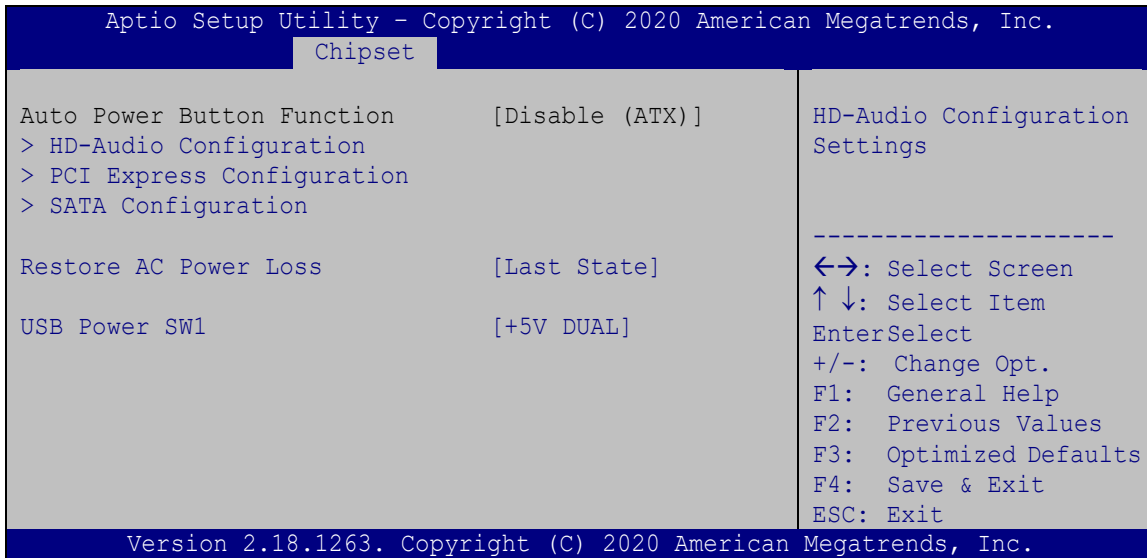

BIOS Menu 18: South Bridge Configuration

AFL3-W07A-AL2 Panel PC

→ Restore on AC Power Loss [Last State]

Use the **Restore on AC Power Loss** BIOS option to specify what state the system returns to if there is a sudden loss of power to the system.

- **Power Off** The system remains turned off
- **Power On** The system turns on
- **Last State** **DEFAULT** The system returns to its previous state. If it was on, it turns itself on. If it was off, it remains off.

→ USB Power SW1 [+5V DUAL]

Use the **USB Power SW1** BIOS option to configure whether to provide power to the external USB 3.2 Gen 1 connectors when the system is in S3/S4 sleep state. This option is valid only when the above **Power Saving Function** BIOS option (see Section 4.3.7) is disabled.

- **+5V DUAL** **DEFAULT** Power is provided to the external USB 3.2 Gen 1 connectors when the system is in S3/S4 sleep state
- **+5V** Power is not provided to the external USB 3.2 Gen 1 connectors when the system is in S3/S4 sleep state

4.4.2.1 HD-Audio Configuration

Use the **HD-Audio Configuration** menu (**BIOS Menu 19**) to configure the HD Audio.

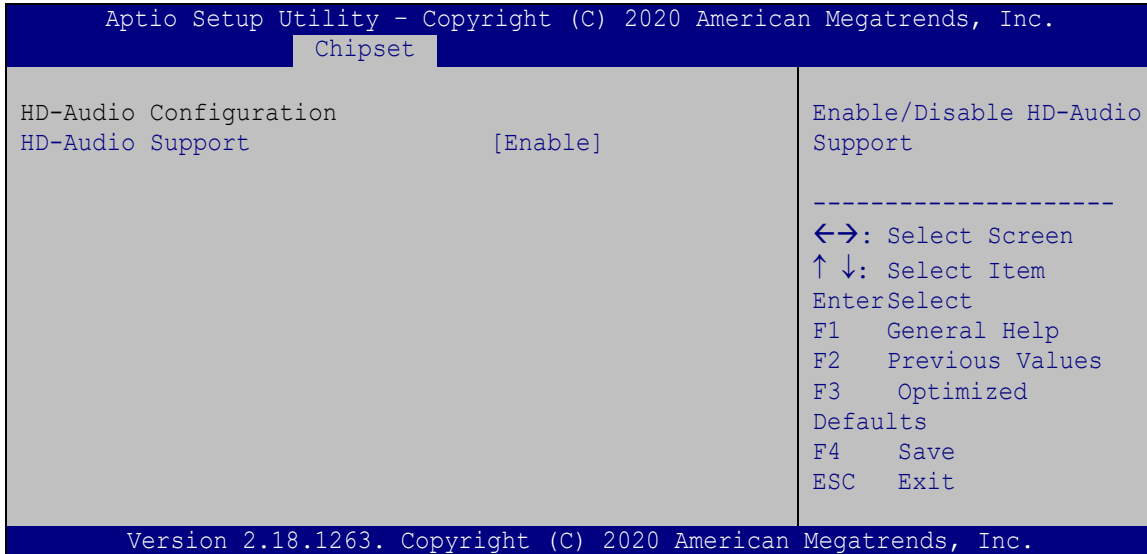

BIOS Menu 19: HD-Audio Configuration

→ HD-Audio Support [Enable]

Use the **HD-Audio Support** option to enable or disable the High Definition Audio controller.

- **Disable** The onboard High Definition Audio controller is disabled
- **Enable** **DEFAULT** The onboard High Definition Audio controller is detected automatically and enabled

AFL3-W07A-AL2 Panel PC

4.4.2.2 PCI Express Configuration

Use the **PCI Express Configuration** menu (**BIOS Menu 20**) to configure the PCI Express.

```

Aptio Setup Utility - Copyright (C) 2020 American Megatrends, Inc.
Chipset
PCI Express Configuration
> M2_AKEY1

Control the PCI Express Root Port.
AUTO: To disable unused root port automatically for the most optimum power savings.
Enable: Enable PCIe root port
Disable: Disable PCIe root port

-----
<=>: Select Screen
↑ ↓: Select Item
Enter>Select
F1   General Help
F2   Previous Values
F3   Optimized
Defaults
F4   Save
ESC  Exit

Version 2.18.1263. Copyright (C) 2020 American Megatrends, Inc.
    
```

BIOS Menu 20: PCI Express Configuration

4.4.2.2.1 M2_AKEY1

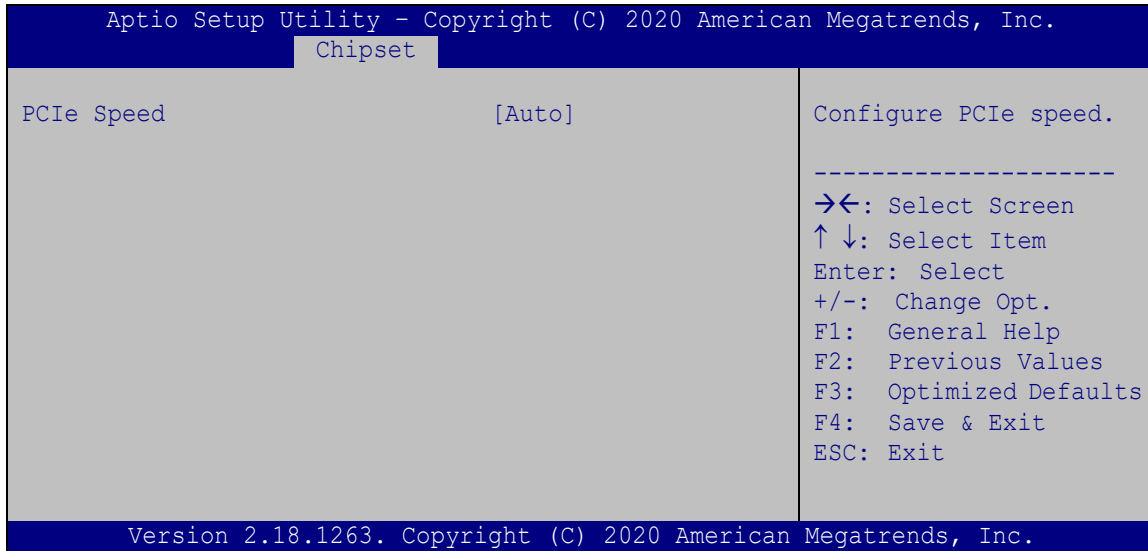

BIOS Menu 21: M2_AKEY1

→ PCIe Speed [Auto]

Use this option to select the support type of the PCI Express slot. The following options are available:

- Auto **Default**
- Gen1
- Gen2

AFL3-W07A-AL2 Panel PC

4.4.2.3 SATA Configuration

Use the **SATA Configuration** menu (**BIOS Menu 22**) to change and/or set the configuration of the SATA devices installed in the system.

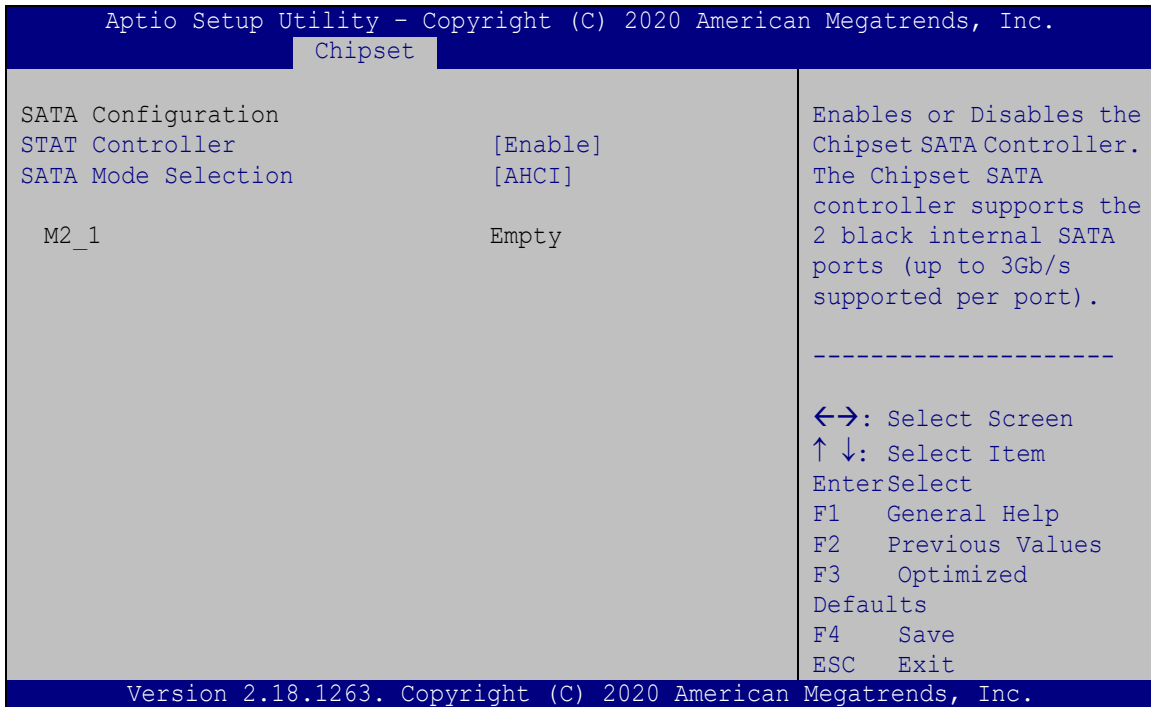

BIOS Menu 22: SATA Configuration

→ STAT Controller [Enable]

Use the **STAT Controller(s)** option to enable or disable the SATA device.

- **Enable** **DEFAULT** Enables the SATA device.
- **Disable** Disables the SATA device.

→ SATA Mode Selection [AHCI]

Use the **SATA Mode Selection** option to configure SATA devices as AHCI devices.

- **AHCI** **DEFAULT** Configures SATA devices as AHCI device.

4.5 Security

Use the **Security** menu (**BIOS Menu 23**) to set system and user passwords.

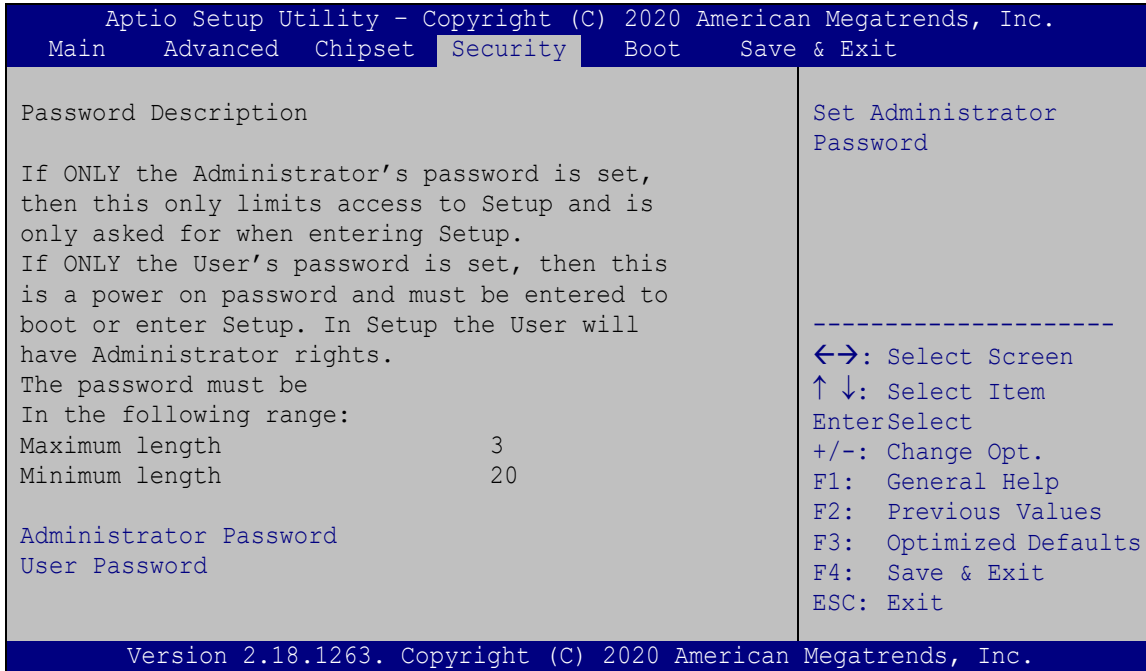

BIOS Menu 23: Security

→ Administrator Password

Use the **Administrator Password** field to set or change an administrator password.

→ User Password

Use the **User Password** field to set or change a user password.

AFL3-W07A-AL2 Panel PC

4.6 Boot

Use the **Boot** menu (**BIOS Menu 24**) to configure system boot options.

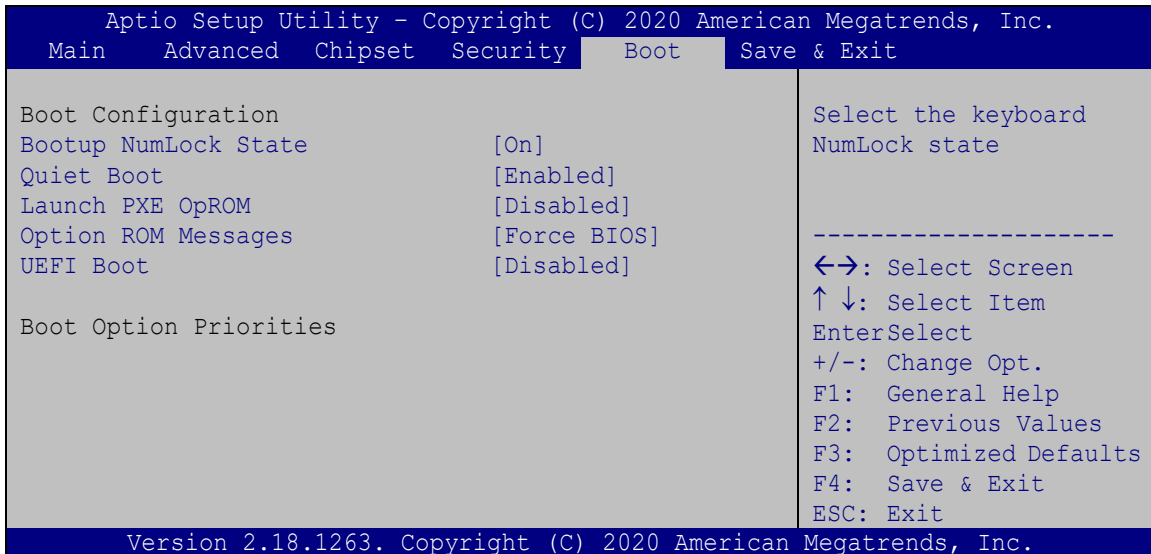

BIOS Menu 24: Boot

→ Bootup NumLock State [On]

Use the **Bootup NumLock State** BIOS option to specify if the number lock setting must be modified during boot up.

→ **On** **DEFAULT** Allows the Number Lock on the keyboard to be enabled automatically when the computer system boots up. This allows the immediate use of the 10-key numeric keypad located on the right side of the keyboard. To confirm this, the Number Lock LED light on the keyboard is lit.

→ **Off** Does not enable the keyboard Number Lock automatically. To use the 10-keys on the keyboard, press the Number Lock key located on the upper left-hand corner of the 10-key pad. The Number Lock LED on the keyboard lights up when the Number Lock is engaged.

→ **Quiet Boot [Enabled]**

Use the **Quiet Boot** BIOS option to select the screen display when the system boots.

- **Disabled** Normal POST messages displayed
- **Enabled** **DEFAULT** OEM Logo displayed instead of POST messages

→ **Launch PXE OpROM [Disabled]**

Use the **Launch PXE OpROM** option to enable or disable boot option for legacy network devices.

- **Disabled** **DEFAULT** Ignore all PXE Option ROMs
- **Enabled** Load PXE Option ROMs

→ **Option ROM Messages [Force BIOS]**

Use the **Option ROM Messages** option to set the Option ROM display mode.

- **Force BIOS** **DEFAULT** Sets display mode to force BIOS.
- **Keep Current** Sets display mode to current.

→ **UEFI Boot [Disabled]**

Use the **UEFI Boot** BIOS option to enable or disable UEFI boot.

- **Enabled** Enable UEFI boot if the 1st boot device is a GPT HDD.
- **Disabled** **DEFAULT** Disable UEFI boot.

AFL3-W07A-AL2 Panel PC

4.7 Save & Exit

Use the **Save & Exit** menu (**BIOS Menu 25**) to load default BIOS values, optimal failsafe values and to save configuration changes.

```

Aptio Setup Utility - Copyright (C) 2020 American Megatrends, Inc.
Main   Advanced  Chipset   Boot     Security  Save & Exit
-----
Save Changes and Reset
Discard Changes and Reset

Restore Defaults
Save as User Defaults
Restore User Defaults

Reset the system after
saving the changes.

-----
<->: Select Screen
↑ ↓: Select Item
Enter>Select
+/-: Change Opt.
F1:  General Help
F2:  Previous Values
F3:  Optimized Defaults
F4:  Save & Exit
ESC: Exit

Version 2.18.1263. Copyright (C) 2020 American Megatrends, Inc.

```

BIOS Menu 25: Save & Exit→ **Save Changes and Reset**

Use the **Save Changes and Reset** option to save the changes made to the BIOS options and reset the system.

→ **Discard Changes and Reset**

Use the **Discard Changes and Reset** option to exit the system without saving the changes made to the BIOS configuration setup program.

→ **Restore Defaults**

Use the **Restore Defaults** option to load the optimal default values for each of the parameters on the Setup menus. **F3 key can be used for this operation.**

→ **Save as User Defaults**

Use the **Save as User Defaults** option to save the changes done so far as user defaults.

→ **Restore User Defaults**

Use the **Restore User Defaults** option to restore the user defaults to all the setup options.

Chapter

5

System Maintenance

5.1 System Maintenance Introduction

If the components of the AFL3-W07A-AL2 fail they must be replaced. Please contact the system reseller or vendor to purchase the replacement parts. Back cover removal instructions for the AFL3-W07A-AL2 are described below.

5.2 Anti-static Precautions



WARNING:

Failure to take ESD precautions during the maintenance of the AFL3-W07A-AL2 may result in permanent damage to the AFL3-W07A-AL2 and severe injury to the user.

Electrostatic discharge (ESD) can cause serious damage to electronic components, including the AFL3-W07A-AL2. Dry climates are especially susceptible to ESD. It is therefore critical that whenever the AFL3-W07A-AL2 is accessed internally, or any other electrical component is handled, the following anti-static precautions are strictly adhered to.

- **Wear an anti-static wristband:** Wearing a simple anti-static wristband can help to prevent ESD from damaging the board.
- **Self-grounding:** Before handling the board, touch any grounded conducting material. During the time the board is handled, frequently touch any conducting materials that are connected to the ground.
- **Use an anti-static pad:** When configuring the AFL3-W07A-AL2, place it on an anti-static pad. This reduces the possibility of ESD damaging the AFL3-W07A-AL2.
- **Only handle the edges of the PCB:** When handling the PCB, hold the PCB by the edges.

AFL3-W07A-AL2 Panel PC

5.3 Turn off the Power

**WARNING:**

Failing to turn off the system before opening it can cause permanent damage to the system and serious or fatal injury to the user.

Before any maintenance procedures are carried out on the system, make sure the system is turned off.

5.4 Removing the Back Cover

**WARNING:**

Over-tightening back cover screws will crack the plastic frame. Maximum torque for cover screws is 5 kg-cm (0.36 lb-ft/0.49 Nm).

To access the AFL3-W07A-AL2 internally the back cover must be removed. To remove the back cover, please follow the steps below.

Step 1: Follow all anti-static procedures. See **Section 5.2**.

Step 2: Turn off the power. See **Section 5.3**.

Step 3: Remove the two retention screws from the back cover (**Figure 5-1**).



Figure 5-1: Back Cover Retention Screws

Step 4: Carefully separate the back cover from the chassis and lift the cover of the device

5.5 WLAN Card Replacement

The AFL3-W07A-AL2 has one WLAN card slot. To replace the WLAN card, follow the instructions below.

Step 1: Follow all anti-static procedures. See **Section 5.2**.

Step 2: Turn off the power. See **Section 5.3**.

Step 3: Remove the back cover. See **Section 5.4** above.

Step 4: Locate the WLAN card (**Figure 5-2**).

AFL3-W07A-AL2 Panel PC

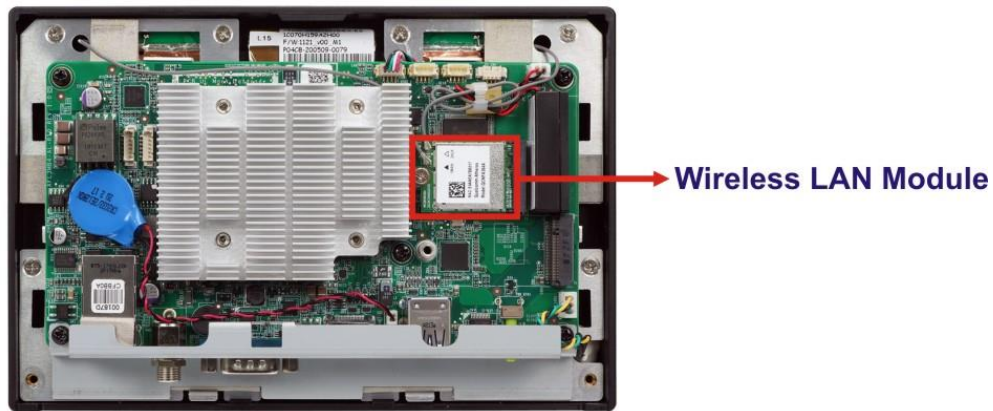

Figure 5-2: WLAN Card Location

- Step 5:** Disconnect the antenna cables on the WLAN module and remove the retention screw to release the WLAN card.
- Step 6:** Grasp the WLAN card by the edges and carefully pull it out of the socket.
- Step 7:** Install a new WLAN card by inserting the card into the slot at an angle.
- Step 8:** Push the WLAN card down and secure it with the previously removed retention screw.
- Step 9:** Connect the antenna cables.
- Step 10:** Replace the back cover and secure it using the previously removed retention screws.

5.6 Reinstalling the Cover



WARNING:

Failing to reinstall the cover may result in permanent damage to the system. Please make sure all coverings are properly installed.

When maintenance procedures are complete, please make sure the plastic back cover is replaced.

Chapter

6

Interface Connectors

AFL3-W07A-AL2 Panel PC

6.1 Peripheral Interface Connectors

The AFL3-W07A-AL2 panel PC motherboard comes with a number of peripheral interface connectors and configuration jumpers. The connector locations are shown in **Figure 6-1**. The Pin 1 locations of the on-board connectors are also indicated in the diagram below. The connector pinouts for these connectors are listed in the following sections.

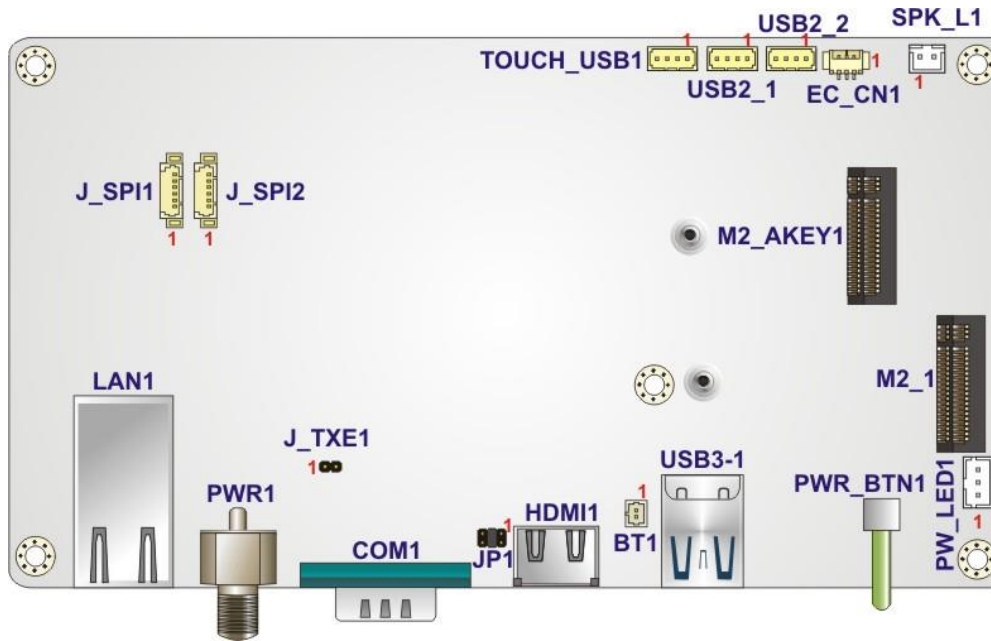

Figure 6-1: Main Board Layout Diagram (Front Side)

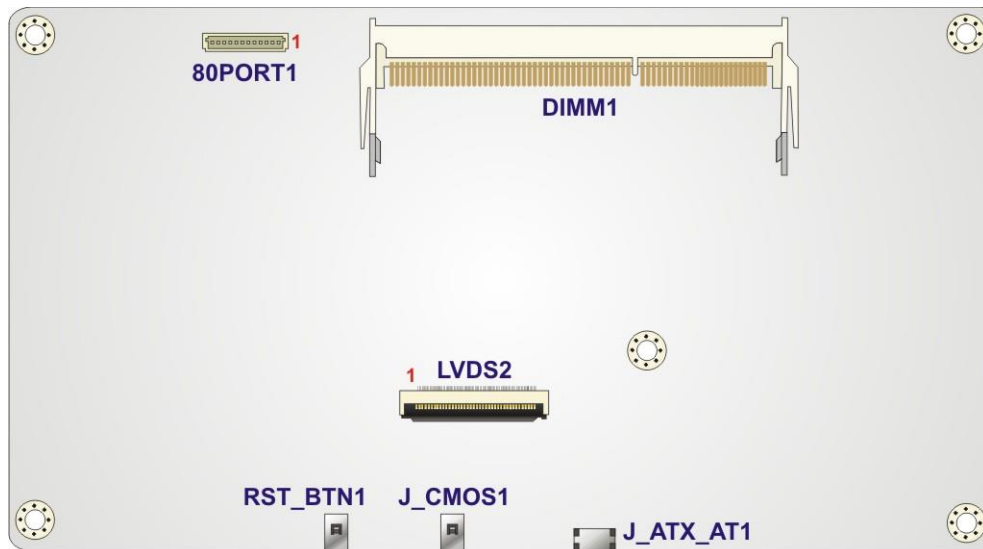

Figure 6-2: Main Board Layout Diagram (Solder Side)

6.2 Internal Peripheral Connectors

Internal peripheral connectors are found on the motherboard and are only accessible when the motherboard is outside of the chassis. The table below shows a list of the peripheral interface connectors on the motherboard. Pinouts of these connectors can be found in the following sections.

Connector	Type	Label
Battery connector	2-pin wafer	BT1
Debug port	12-pin wafer	80PORT1
LVDS connector	40-pin FPC	LVDS2
M.2 A-key slot	M.2 A-key	M2_AKEY1
M.2 B-key slot	M.2 B-key	M2_1
Power LED connector	3-pin wafer	PW_LED1
SMBus connector	3-pin wafer	EC_CN1
Speaker connector	2-pin wafer	SPK_L1
SPI Flash connector	6-pin wafer	J_SPI1
EC Flash connector	6-pin wafer	J_SPI2
USB 2.0 connector	4-pin wafer	TOUCH_USB1
USB 2.0 connectors	4-pin wafer	USB2_1, USB2_2

Table 6-1: Peripheral Interface Connectors

6.2.1 Battery Connector (BT1)

PIN NO.	DESCRIPTION
1	+3.3V
2	GND

Table 6-2: Battery Connector (BT1) Pinouts

AFL3-W07A-AL2 Panel PC

6.2.2 Debug Port Connector (80PORT1)

PIN NO.	DESCRIPTION	PIN NO.	DESCRIPTION
1	+5V(Reserved)	7	LPC_AD1
2	+3.3V	8	LPC_ADO
3	GND	9	LPC_FRAME_N
4	LPC_SERIRQ	10	PLT_RST#
5	LPC_AD3	11	LPC_CLOCK
6	LPC_AD2	12	GND

Table 6-3: Debug Port Connector (80PORT1) Pinouts

6.2.3 LVDS Connector (LVDS2)

PIN NO.	DESCRIPTION	PIN NO.	DESCRIPTION
1	VCC_LCD_COM	21	LVDSA3+
2	+VCC_LCD2	22	GND
3	+VCC_LCD2	23	NC
4	NC	24	NC
5	LCD_RST_IN_3V3	25	GND
6	LCD_STBY_IN_3V3-	26	NC
7	GND	27	LCD_DIMO
8	LVDSA0-	28	LCD_SELB
9	LVDSA0+	29	VCC_LCD_AVDD
10	GND	30	GND
11	LVDSA1-	31	VLED-
12	LVDSA1+	32	VLED-
13	GND	33	LCD_LR
14	LVDSA2-	34	LCD_UD
15	LVDSA2+	35	LCD_VGL
16	GND	36	LCD_CABC_EN1
17	LVDSACLK-	37	LCD_CABC_EN0
18	LVDSACLK+	38	LCD_VGH
19	GND	39	VLED+

20	LVDSA3-	40	VLED+
----	---------	----	-------

Table 6-4: LVDS Connector (LVDS2) Pinouts

6.2.4 M.2 A-Key Slot (M2_AKEY1)

PIN NO.	DESCRIPTION	PIN NO.	DESCRIPTION
1	GND	2	+V3.3A
3	USB+	4	+V3.3A
5	USB-	6	NC
7	GND	8	Module Key
9	Module Key	10	Module Key
11	Module Key	12	Module Key
13	Module Key	14	Module Key
15	Module Key	16	NC
17	NC	18	GND
19	NC	20	NC
21	NC	22	NC
23	GND	24	GND
25	NC	26	NC
27	NC	28	NC
29	GND	30	GND
31	NC	32	NC
33	GND	34	NC
35	PCIE_TX+	36	GND
37	PCIE_TX-	38	NC
39	GND	40	NC
41	PCIE_RX+	42	NC
43	PCIE_RX-	44	NC
45	GND	46	NC
47	CLK_PCIE+	48	NC
49	CLK_PCIE-	50	NC
51	GND	52	BUF_PLT_RST#
53	PCIE_CLKREQ#	54	Pull Up +V3.3A

AFL3-W07A-AL2 Panel PC

55	PCIE_WAKE#	56	Pull Up +V3.3A
57	GND	58	NC
59	NC	60	NC
61	NC	62	NC
63	GND	64	NC
65	NC	66	NC
67	NC	68	NC
69	GND	70	NC
71	NC	72	+V3.3A
73	NC	74	+V3.3A
75	GND		

Table 6-5: M.2 A-Key Slot (M2_AKEY1) Pinouts

6.2.5 M.2 B-Key Slot (M2_1)

PIN NO.	DESCRIPTION	PIN NO.	DESCRIPTION
1	GND	2	VCC3
3	GND	4	VCC3
5	GND	6	N/C
7	USB_+DATA6	8	N/C
9	USB_-DATA6	10	N/C
11	N/C	20	N/C
21	N/C	22	N/C
23	GND	24	N/C
25	N/C	26	N/C
27	N/C	28	N/C
29	USB3_RX2_N	30	N/C
31	USB3_RX2_P	32	N/C
33	GND	34	N/C
35	USB3P0_TXDNM2	36	N/C
37	USB3P0_TXDPM2	38	GND
39	GND	40	N/C
41	M1_SATA_RX1+_C	42	N/C

43	M1_SATA_RX1-_C	44	N/C
45	GND	46	N/C
47	M1_SATA_TX1-_C	48	N/C
49	M1_SATA_TX1+_C	50	N/C
51	GND	52	N/C
53	N/C	54	GND
55	N/C	56	N/C
57	GND	58	N/C
59	N/C	60	N/C
61	N/C	62	N/C
63	GND	64	N/C
65	N/C	66	N/C
67	Reset	68	N/C
69	N/C	70	VCC3
71	GND	72	VCC3
73	GND	74	VCC3
75	GND		

Table 6-6: M.2 B-Key Slot (M2_1) Pinouts

6.2.6 Power LED Connector (PW_LED1)

PIN NO.	DESCRIPTION
1	+5VS
2	GND
3	+5VA

Table 6-7: Power LED Connector (PW_LED1) Pinouts

AFL3-W07A-AL2 Panel PC

6.2.7 SMBus Connector (EC_CN1)

PIN NO.	DESCRIPTION
1	SMCLK_EC
2	SMDATA_EC
3	N/C

Table 6-8: SMBus Connector (EC_CN1) Pinouts

6.2.8 Speaker Connector, Left (SPK_L1)

PIN NO.	DESCRIPTION
1	SPK_OUT_L+
2	SPK_OUT_L-

Table 6-9: Left Speaker Connector (SPK_L1) Pinouts

6.2.9 SPI Flash Connector (J_SPI1)

PIN NO.	DESCRIPTION
1	+3.3V
2	SPI_CS
3	SPI_SO_SW
4	SPI_CLK_SW
5	SPI_SI_SW
6	GND

Table 6-10: SPI Flash Connector (J_SPI1) Pinouts

6.2.10 SPI Flash Connector, EC (J_SPI2)

PIN NO.	DESCRIPTION
1	+3.3V
2	SPI_CS
3	SPI_SO_SW
4	SPI_CLK_SW
5	SPI_SI_SW
6	GND

Table 6-11: EC SPI Flash Connector (J_SPI2) Pinouts

6.2.11 USB 2.0 Connector (TOUCH_USB1)

PIN NO.	DESCRIPTION
1	+5V
2	USB_DATA-
3	USB_DATA+
4	GND

Table 6-12: USB 2.0 Connector (TOUCH_USB1) Pinouts

6.2.12 USB 2.0 Connectors (USB2_1, USB2_2)

PIN NO.	DESCRIPTION
1	+5V
2	USB_DATA-
3	USB_DATA+
4	GND

Table 6-13: USB 2.0 Connectors (USB2_1, USB2_2) Pinouts

AFL3-W07A-AL2 Panel PC

6.3 External Interface Panel Connectors

The table below lists the rear panel connectors on the AFL2MB-15A motherboard. Pinouts of these connectors can be found in the following sections.

Connector	Type	Label
Ethernet connector	RJ-45	LAN1
HDMI connector	HDMI port	HDMI1
Power button	Push button	PWR_BTN1
Power connector	Power jack	PWR1
RS-232/422/485 connector	DB-9	COM1
USB 3.0 connectors	USB 3.2 Gen 1 Type A	USB3-1

Table 6-14: Rear Panel Connectors

6.3.1 Ethernet Connectors (LAN1)

PIN NO.	DESCRIPTION	PIN NO.	DESCRIPTION
1	MDIA0+	5	MDIA2-
2	MDIA0-	6	MDIA1-
3	MDIA1+	7	MDIA3+
4	MDIA2+	8	MDIA3-

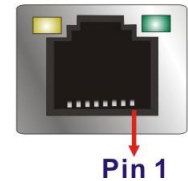

Table 6-15: Ethernet Connectors (LAN1) Pinouts

LED	Description	LED	Description
A	on: linked blinking: data is being sent/received	B	off: 10 Mb/s green: 100 Mb/s orange: 1000 Mb/s

Table 6-16: Ethernet Connector LEDs

6.3.2 HDMI Connector (HDMI1)

PIN NO.	DESCRIPTION	PIN NO.	DESCRIPTION
1	HDMI_DATA2	2	GND
3	HDMI_DATA2#	4	HDMI_DATA1
5	GND	6	HDMI_DATA1#
7	HDMI_DATA0	8	GND
9	HDMI_DATA0#	10	HDMI_CLK
11	GND	12	HDMI_CLK#
13	N/C	14	N/C
15	HDMI_SCL	16	HDMI_SDA
17	GND	18	+5V
19	HDMI_HPD	20	HDMI_GND
21	HDMI_GND	22	HDMI_GND
23	HDMI_GND		

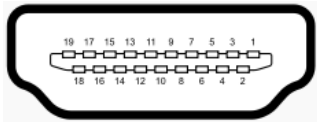

Table 6-17: HDMI Connector (HDMI1) Pinouts

6.3.3 RS-232/422/485 DB-9 Serial Port (COM1)

PIN NO.	DESCRIPTION	PIN NO.	DESCRIPTION
1	NDCD	6	NDSR
2	NRX	7	NRTS
3	NTX	8	NCTS
4	NDTR	9	NRI
5	GND		

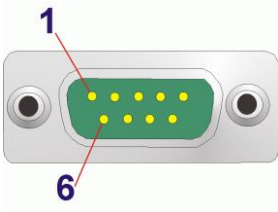

Table 6-18: RS-232/422/485 DB-9 Serial Port (COM1) Pinouts

AFL3-W07A-AL2 Panel PC

6.3.4 Power Connector (PWR1)

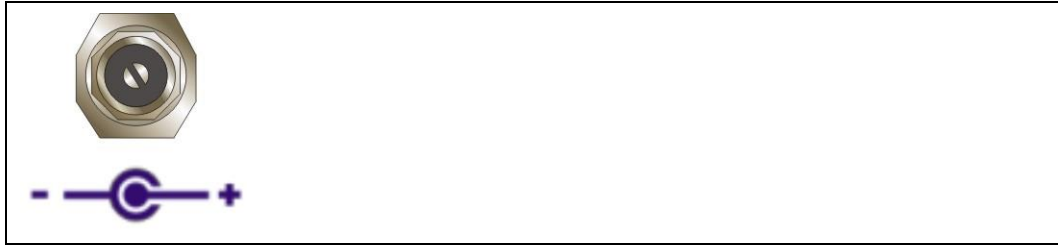

Table 6-19: Power Connector (PWR1) Pinouts

6.3.5 USB 3.2 Gen 1 Connectors (USB3-1)

PIN NO.	DESCRIPTION	PIN NO.	DESCRIPTION
1	USB3_PWR1	10	USB3_PWR2
2	USB2P0_DM1_L	11	USB2P0_DM2_L
3	USB2P0_DP1_L	12	USB2P0_DP2_L
4	GND	13	GND
5	USB3P0_RXDN1_L	14	USB3P0_RXDN2_L
6	USB3P0_RXDP1_L	15	USB3P0_RXDP2_L
7	GND	16	GND
8	USB3P0_TXDN1_C_L	17	USB3P0_TXDN2_C_L
9	USB3P0_TXDP1_C_L	18	USB3P0_TXDP2_C_L

Table 6-20: USB 3.2 Gen 1 Connectors (USB3-1) Pinouts

Appendix

A

Regulatory Compliance

DECLARATION OF CONFORMITY

This equipment is in conformity with the following EU directives:

- EMC Directive 2014/30/EU
- Low-Voltage Directive 2014/35/EU
- RoHS II Directive 2015/863/EU

If the user modifies and/or install other devices in the equipment, the CE conformity declaration may no longer apply.

If this equipment has telecommunications functionality, it also complies with the requirements of the R&TTE Directive 1999/5/EC.

English

IEI Integration Corp declares that this equipment is in compliance with the essential requirements and other relevant provisions of Directive 1999/5/EC.

Български [Bulgarian]

IEI Integration Corp. декларира, че този оборудване е в съответствие със съществените изисквания и другите приложими правила на Директива 1999/5/EC.

Česky [Czech]

IEI Integration Corp tímto prohlašuje, že tento zařizení je ve shodě se základními požadavky a dalšími příslušnými ustanoveními směrnice 1999/5/S.

Dansk [Danish]

IEI Integration Corp erklærer herved, at følgende udstyr overholder de væsentlige krav og øvrige relevante krav i direktiv 1999/5/EF.

Deutsch [German]

IEI Integration Corp, erklärt dieses Gerät entspricht den grundlegenden Anforderungen und den weiteren entsprechenden Vorgaben der Richtlinie 1999/5/EU.

Eesti [Estonian]

IEI Integration Corp deklareerib seadme seadme vastavust direktiivi 1999/5/EÜ põhinõuetele ja nimetatud direktiivist tulenevatele teistele asjakohastele sätetele.

Español [Spanish]

IEI Integration Corp declara que el equipo cumple con los requisitos esenciales y cualesquiera otras disposiciones aplicables o exigibles de la Directiva 1999/5/CE.

Ελληνική [Greek]

IEI Integration Corp ΔΗΛΩΝΕΙ ΟΤΙ ΕΞΟΠΛΙΣΜΟΣ ΣΥΜΜΟΡΦΩΝΕΤΑΙ ΠΡΟΣ ΤΙΣ ΟΥΣΙΩΔΕΙΣ ΑΠΑΙΤΗΣΕΙΣ ΚΑΙ ΤΙΣ ΛΟΙΠΕΣ ΣΧΕΤΙΚΕΣ ΔΙΑΤΑΞΕΙΣ ΤΗΣ ΟΔΗΓΙΑΣ 1999/5/EK.

Français [French]

IEI Integration Corp déclare que l'appareil est conforme aux exigences essentielles et aux autres dispositions pertinentes de la directive 1999/5/CE.

Italiano [Italian]

IEI Integration Corp dichiara che questo apparecchio è conforme ai requisiti essenziali ed alle altre disposizioni pertinenti stabilite dalla direttiva 1999/5/CE.

Latviski [Latvian]

IEI Integration Corp deklarē, ka iekārta atbilst būtiskajām prasībām un citiem ar to saistītajiem noteikumiem Direktīvas 1999/5/EK.

Lietuvių [Lithuanian]

IEI Integration Corp deklaruoja, kad šis įranga atitinka esminius reikalavimus ir kitas 1999/5/EB Direktyvos nuostatas.

Nederlands [Dutch]

IEI Integration Corp dat het toestel in overeenstemming is met de essentiële eisen en de andere relevante bepalingen van richtlijn 1999/5/EG.

Malti [Maltese]

IEI Integration Corp jiddikjara li dan prodott jikkonforma mal-ħtiġijiet essenzjali u ma provvedimenti oħrajn relevanti li hemm fid-Dirrettiva 1999/5/EC.

Magyar [Hungarian]

IEI Integration Corp nyilatkozom, hogy a berendezés megfelel a vonatkozó alapvető követelményeknek és az 1999/5/EC irányelv egyéb előírásainak.

Polski [Polish]

IEI Integration Corp oświadcza, że wyrobu jest zgodny z zasadniczymi wymogami oraz pozostałymi stosownymi postanowieniami Dyrektywy 1999/5/EC.

Português [Portuguese]

IEI Integration Corp declara que este equipamento está conforme com os requisitos essenciais e outras disposições da Directiva 1999/5/CE.

AFL3-W07A-AL2 Panel PC

Româna [Romanian]

IEI Integration Corp declară că acest echipament este în conformitate cu cerințele esențiale și cu celelalte prevederi relevante ale Directivei 1999/5/CE.

Slovensko [Slovenian]

IEI Integration Corp izjavlja, da je ta opreme v skladu z bistvenimi zahtevami in ostalimi relevantnimi določili direktive 1999/5/ES.

Slovensky [Slovak]

IEI Integration Corp týmto vyhlasuje, že zariadenia spĺňa základné požiadavky a všetky príslušné ustanovenia Smernice 199/5/ES.

Suomi [Finnish]

IEI Integration Corp vakuuttaa täten että laitteet on direktiivin 1999/5/EY oleellisten vaatimusten ja sitä koskevien direktiivin muiden ehtojen mukainen.

Svenska [Swedish]

IEI Integration Corp förklarar att denna utrustningstyp står i överensstämmelse med de väsentliga egenskapskrav och övriga relevanta bestämmelser som framgår av direktiv 1999/5/EG.

ROHS STATEMENT



The label on the product indicates this product conforms to European (EU) Restriction of Hazardous Substances (RoHS) that set maximum concentration limits on hazardous materials used in electrical and electronic equipment.

FCC WARNING

This equipment complies with Part 15 of the FCC Rules. Operation is subject to the following two conditions:

- This device may not cause harmful interference, and
- This device must accept any interference received, including interference that may cause undesired operation.

This equipment has been tested and found to comply with the limits for a Class A digital device, pursuant to part 15 of the FCC Rules. These limits are designed to provide reasonable protection against harmful interference when the equipment is operated in a commercial environment. This equipment generates, uses, and can radiate radio frequency energy and, if not installed and used in accordance with the instruction manual, may cause harmful interference to radio communications. Operation of this equipment in a residential area is likely to cause harmful interference in which case the user will be required to correct the interference at his own expense.

Any changes or modifications not expressly approved by the party responsible for compliance could void the user's authority to operate the equipment.

This equipment complies with FCC radiation exposure limits set forth for an uncontrolled environment. This equipment should be installed and operated with a minimum distance of 20cm between the radiator & your body.

CHINA ROHS

The label on the product indicates the estimated “Environmentally Friendly Use Period” (EFUP). This is an estimate of the number of years that these substances would “not leak out or undergo abrupt change.” This product may contain replaceable sub-assemblies/ components which have a shorter EFUP such as batteries and lamps. These components will be separately marked.

Appendix

B

Safety Precautions

**WARNING:**

The precautions outlined in this chapter should be strictly followed. Failure to follow these precautions may result in permanent damage to the AFL3-W07A-AL2.

B.1 Safety Precautions

Please follow the safety precautions outlined in the sections that follow:

B.1.1 General Safety Precautions

Please ensure the following safety precautions are adhered to at all times.

- Follow the electrostatic precautions outlined below whenever the AFL3-W07A-AL2 is opened.
- Make sure the power is turned off and the power cord is disconnected whenever the AFL3-W07A-AL2 is being installed, moved or modified.
- Do not apply voltage levels that exceed the specified voltage range. Doing so may cause fire and/or an electrical shock.
- Electric shocks can occur if the AFL3-W07A-AL2 chassis is opened when the AFL3-W07A-AL2 is running.
- Do not drop or insert any objects into the ventilation openings of the AFL3-W07A-AL2.
- If considerable amounts of dust, water, or fluids enter the AFL3-W07A-AL2, turn off the power supply immediately, unplug the power cord, and contact the AFL3-W07A-AL2 vendor.
- This equipment is not suitable for use in locations where children are likely to be present.
- **DO NOT:**
 - Drop the AFL3-W07A-AL2 against a hard surface.
 - Strike or exert excessive force onto the LCD panel.
 - Touch any of the LCD panels with a sharp object
 - In a site where the ambient temperature exceeds the rated temperature

AFL3-W07A-AL2 Panel PC

B.1.2 Anti-static Precautions



WARNING:

Failure to take ESD precautions during the installation of the AFL3-W07A-AL2 may result in permanent damage to the AFL3-W07A-AL2 and severe injury to the user.

Electrostatic discharge (ESD) can cause serious damage to electronic components, including the AFL3-W07A-AL2. Dry climates are especially susceptible to ESD. It is therefore critical that whenever the AFL3-W07A-AL2 is opened and any of the electrical components are handled, the following anti-static precautions are strictly adhered to.

- ***Wear an anti-static wristband:*** Wearing a simple anti-static wristband can help to prevent ESD from damaging any electrical component.
- ***Self-grounding:*** Before handling any electrical component, touch any grounded conducting material. During the time the electrical component is handled, frequently touch any conducting materials that are connected to the ground.
- ***Use an anti-static pad:*** When configuring or working with an electrical component, place it on an anti-static pad. This reduces the possibility of ESD damage.
- ***Only handle the edges of the electrical component:*** When handling the electrical component, hold the electrical component by its edges.

B.1.3 Product Disposal

**CAUTION:**

Risk of explosion if the battery is replaced by an incorrect type;

Replacement of a battery with an incorrect type that can defeat a safeguard (for example, in the case of some lithium battery types);

Disposal of a battery into fire or a hot oven, or mechanically crushing or cutting of a battery, that can result in an explosion;

Leaving a battery in an extremely high temperature surrounding environment that can result in an explosion or the leakage of flammable liquid or gas;

A battery subjected to extremely low air pressure that may result in an explosion or the leakage of flammable liquid or gas.

Dispose of used batteries according to instructions and local regulations.

- Outside the European Union - If you wish to dispose of used electrical and electronic products outside the European Union, please contact your local authority so as to comply with the correct disposal method.
- Within the European Union:

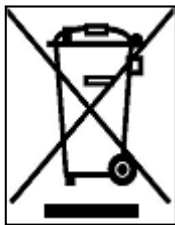

EU-wide legislation, as implemented in each Member State, requires that waste electrical and electronic products carrying the mark (left) must be disposed of separately from normal household waste. This includes monitors and electrical accessories, such as signal cables or power cords. When you need to dispose of your display products, please follow the guidance of your local authority, or ask the shop where you purchased the product. The mark on electrical and electronic products only applies to the current European Union Member States.

Please follow the national guidelines for electrical and electronic product disposal.

AFL3-W07A-AL2 Panel PC

B.2 Maintenance and Cleaning Precautions

When maintaining or cleaning the AFL3-W07A-AL2, please follow the guidelines below.

B.2.1 Maintenance and Cleaning

Prior to cleaning any part or component of the AFL3-W07A-AL2, please read the details below.

- Except for the LCD panel, never spray or squirt liquids directly onto any other components. To clean the LCD panel, gently wipe it with a piece of soft dry cloth or a slightly moistened cloth.
- Never use alcohol to clean the external chassis.
- The interior of the AFL3-W07A-AL2 does not require cleaning. Keep fluids away from the AFL3-W07A-AL2 interior.
- Be cautious of all small removable components when vacuuming the AFL3-W07A-AL2.
- Turn the AFL3-W07A-AL2 off before cleaning the AFL3-W07A-AL2.
- Never drop any objects or liquids through the openings of the AFL3-W07A-AL2.
- Be cautious of any possible allergic reactions to solvents or chemicals used when cleaning the AFL3-W07A-AL2.
- Avoid eating, drinking and smoking within vicinity of the AFL3-W07A-AL2.

B.2.2 Cleaning Tools

Some components in the AFL3-W07A-AL2 may only be cleaned using a product specifically designed for the purpose. In such case, the product will be explicitly mentioned in the cleaning tips. Below is a list of items to use when cleaning the AFL3-W07A-AL2.

- **Cloth** – Although paper towels or tissues can be used, a soft, clean piece of cloth is recommended when cleaning the AFL3-W07A-AL2.
- **Water** – A cloth moistened with water can be used to clean the AFL3-W07A-AL2.
- **Using solvents** – The use of solvents is not recommended when cleaning the AFL3-W07A-AL2 as they may damage the plastic parts.

- **Vacuum cleaner** – Using a vacuum specifically designed for computers is one of the best methods of cleaning the AFL3-W07A-AL2. Dust and dirt can restrict the airflow in the AFL3-W07A-AL2 and cause its circuitry to corrode.
- **Cotton swabs** - Cotton swabs moistened with water are excellent tools for wiping hard to reach areas.
- **Foam swabs** - Whenever possible, it is best to use lint free swabs such as foam swabs for cleaning.

Appendix

C

BIOS Menu Options

System Date [xx/xx/xx]	43
System Time [xx:xx:xx]	44
ACPI Sleep State [S3 (Suspend to RAM)]	45
Serial Port [Enabled]	47
Transfer Mode [RS232]	47
Hardware Health Status	48
USB Devices	49
Legacy USB Support [Enabled]	49
EIST [Enabled]	50
C-States [Disabled]	50
Intel Virtualization Technology [Disabled]	51
VT-d [Disabled]	51
Wake System with Fixed Time [Disabled]	52
Power Saving Function(ERP) [Disabled]	53
Console Redirection [Disabled]	53
Legacy Serial Redirection Port [COM1]	54
Auto Recovery Function [Disabled]	55
Primary Display [IGD]	58
DVMT Pre-Allocated [256M]	58
DVMT Total Gfx Mem [MAX]	58
Primary IGFX Boot Display [Auto]	59
Backlight Control Mode [LED]	60
Backlight Control Type [PWM]	60
Restore on AC Power Loss [Last State]	61
USB Power SW1 [+5V DUAL]	61
HD-Audio Support [Enable]	62
PCIe Speed [Auto]	64
STAT Controller [Enable]	65
SATA Mode Selection [AHCI]	65
Administrator Password	66
User Password	66
Bootup NumLock State [On]	67
Quiet Boot [Enabled]	68
Launch PXE OpROM [Disabled]	68
Option ROM Messages [Force BIOS]	68

AFL3-W07A-AL2 Panel PC

UEFI Boot [Disabled]	68
Save Changes and Reset	69
Discard Changes and Reset	69
Restore Defaults	69
Save as User Defaults	70
Restore User Defaults	70

Appendix

D

Watchdog Timer

AFL3-W07A-AL2 Panel PC

**NOTE:**

The following discussion applies to DOS. Contact IEI support or visit the IEI website for drivers for other operating systems.

The Watchdog Timer is a hardware-based timer that attempts to restart the system when it stops working. The system may stop working because of external EMI or software bugs. The Watchdog Timer ensures that standalone systems like ATMs will automatically attempt to restart in the case of system problems.

A BIOS function call (INT 15H) is used to control the Watchdog Timer.

INT 15H:

AH – 6FH Sub-function:	
AL – 2:	Sets the Watchdog Timer's period.
BL:	Time-out value (Its unit-second is dependent on the item "Watchdog Timer unit select" in CMOS setup).

Table D-1: AH-6FH Sub-function

Call sub-function 2 to set the time-out period of Watchdog Timer first. If the time-out value is not zero, the Watchdog Timer starts counting down. When the timer value reaches zero, the system resets. To ensure that this reset condition does not occur, calling sub-function 2 must periodically refresh the Watchdog Timer. However, the watchdog timer is disabled if the time-out value is set to zero.

A tolerance of at least 10% must be maintained to avoid unknown routines within the operating system (DOS), such as disk I/O that can be very time-consuming.

**NOTE:**

The Watchdog Timer is activated through software. The software application that activates the Watchdog Timer must also deactivate it when closed. If the Watchdog Timer is not deactivated, the system will automatically restart after the Timer has finished its countdown.

EXAMPLE PROGRAM:

```
; INITIAL TIMER PERIOD COUNTER
```

```
;
```

```
W_LOOP:
```

```
;
```

```
    MOV     AX, 6F02H      ;setting the time-out value  
    MOV     BL, 30        ;time-out value is 48 seconds  
    INT     15H
```

```
;
```

```
; ADD THE APPLICATION PROGRAM HERE
```

```
;
```

```
    CMP     EXIT_AP, 1    ;is the application over?  
    JNE     W_LOOP       ;No, restart the application
```

```
    MOV     AX, 6F02H    ;disable Watchdog Timer  
    MOV     BL, 0       ;  
    INT     15H
```

```
;
```

```
; EXIT ;
```

Appendix

E

Error Beep Code

E.1 PEI Beep Codes

Number of Beeps	Description
1	Memory not Installed
1	Memory was installed twice (InstallPeiMemory routine in PEI Core called twice)
2	Recovery started
3	DXE IPL was not found
3	DXE Core Firmware Volume was not found
4	Recovery failed
4	S3 Resume failed
7	Reset PPI is not available

E.2 DXE Beep Codes

Number of Beeps	Description
1	Invalid password
4	Some of the Architectural Protocols are not available
5	No Console Output Devices are found
5	No Console Input Devices are found
6	Flash update is failed
7	Reset protocol is not available
8	Platform PCI resource requirements cannot be met



NOTE:

If you have any question, please contact IEI for further assistance.

Appendix

F

Hazardous Materials Disclosure

F.1 RoHS II Directive (2015/863/EU)

The details provided in this appendix are to ensure that the product is compliant with the RoHS II Directive (2015/863/EU). The table below acknowledges the presences of small quantities of certain substances in the product, and is applicable to RoHS II Directive (2015/863/EU).

Please refer to the following table.

Part Name	Toxic or Hazardous Substances and Elements									
	Lead (Pb)	Mercury (Hg)	Cadmium (Cd)	Hexavalent Chromium (CR(VI))	Polybrominated Biphenyls (PBB)	Polybrominated Diphenyl Ethers (PBDE)	Bis(2-ethylhexyl) phthalate (DEHP)	Butyl benzyl phthalate (BBP)	Dibutyl phthalate (DBP)	Diisobutyl phthalate (DIBP)
Housing	O	O	O	O	O	O	O	O	O	O
Printed Circuit Board	O	O	O	O	O	O	O	O	O	O
Metal Fasteners	O	O	O	O	O	O	O	O	O	O
Cable Assembly	O	O	O	O	O	O	O	O	O	O
Fan Assembly	O	O	O	O	O	O	O	O	O	O
Power Supply Assemblies	O	O	O	O	O	O	O	O	O	O
Battery	O	O	O	O	O	O	O	O	O	O
<p>O: This toxic or hazardous substance is contained in all of the homogeneous materials for the part is below the limit requirement in Directive (EU) 2015/863.</p> <p>X: This toxic or hazardous substance is contained in at least one of the homogeneous materials for this part is above the limit requirement in Directive (EU) 2015/863.</p>										

AFL3-W07A-AL2 Panel PC

F.2 China RoHS

此附件旨在确保本产品符合中国 RoHS 标准。以下表格标示此产品中某有毒物质的含量符合中国 RoHS 标准规定的限量要求。

本产品上会附有“环境友好使用期限”的标签，此期限是估算这些物质“不会有泄漏或突变”的年限。本产品可能包含有较短的环境友好使用期限的可替换元件，像是电池或灯管，这些元件将会单独标示出来。

部件名称	有毒有害物质或元素					
	铅 (Pb)	汞 (Hg)	镉 (Cd)	六价铬 (CR(VI))	多溴联苯 (PBB)	多溴二苯醚 (PBDE)
壳体	○	○	○	○	○	○
印刷电路板	○	○	○	○	○	○
金属螺帽	○	○	○	○	○	○
电缆组装	○	○	○	○	○	○
风扇组装	○	○	○	○	○	○
电力供应组装	○	○	○	○	○	○
电池	○	○	○	○	○	○

○: 表示该有毒有害物质在该部件所有物质材料中的含量均在 SJ/T11364-2014 與 GB/T26572-2011 标准规定的限量要求以下。

X: 表示该有毒有害物质至少在该部件的某一均质材料中的含量超出 SJ/T11364-2014 與 GB/T26572-2011 标准规定的限量要求。